



Translation of the Original Operating Manual

For professional use.
Always follow the information in this manual,
particularly the safety instructions and the warning
instructions. Store the manual in a safe place.

Version 01/2018

Cobra 40-10
Cobra 40-25

High-pressure
Double Diaphragm Pumps

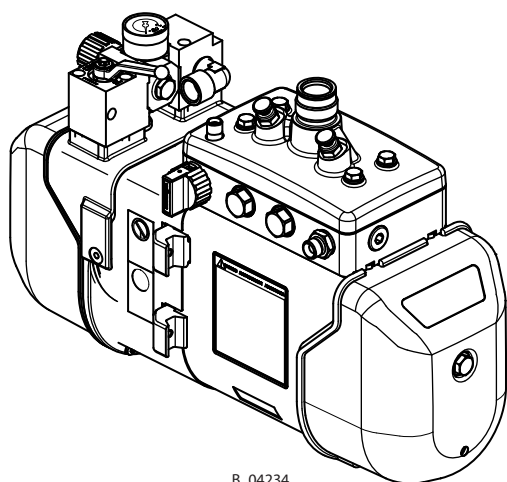

B_04234

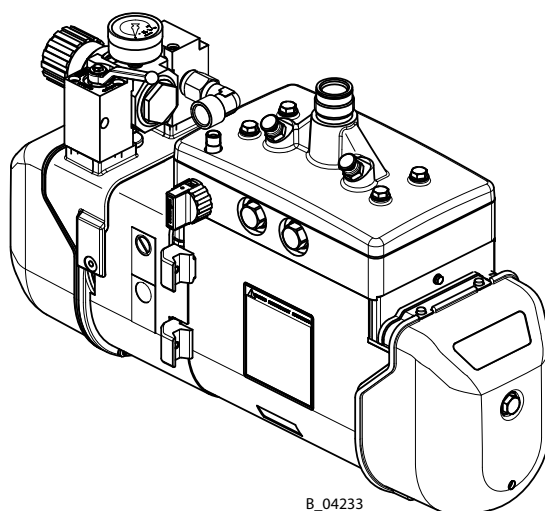

B_04233

Table of Contents

1	ABOUT THESE INSTRUCTIONS	6
1.1	Preface	6
1.2	Warnings, Notices and Symbols in these Instructions	6
1.3	Languages	7
1.4	Abbreviations	7
1.5	Terminology for the Purpose of this Manual	7
2	CORRECT USE	8
2.1	Device types	8
2.2	Type of Use	8
2.3	For Use in Potentially Explosive Areas	8
2.4	Processible Working Materials	9
2.5	Misuse	9
3	IDENTIFICATION	10
3.1	Explosion protection identification	10
3.2	Identification "X"	10
3.3	Type plates	11
4	BASIC SAFETY INSTRUCTIONS	12
4.1	Safety instructions for the operator	12
4.1.1	Electrical Devices and Equipment	12
4.1.2	A Safe Work Environment	12
4.1.3	Personnel Qualifications	13
4.2	Safety Instructions for Staff	13
4.2.1	Personal Safety Equipment	13
4.2.2	Safe handling of WAGNER spray devices	14
4.2.3	Ground the Unit	14
4.2.4	Product hose	15
4.2.5	Cleaning and Flushing	16
4.2.6	Touching hot surfaces	16
4.2.7	Maintenance and Repair	17
4.2.8	Protective and monitoring equipment	17
5	DESCRIPTION	18
5.1	Components	18
5.2	Mode of operation	18
5.2.1	Air motor	18
5.2.2	Fluid section	18
5.3	Protective and monitoring equipment	19
5.4	Included items	19
5.5	Data	19
5.5.1	Materials of paint wetted parts	19
5.5.2	Technical data	20
5.5.3	Dimensions and connections	21
5.5.4	Volume flow	22
5.5.5	Performance diagrams	23
5.6	Cobra Pressure Regulator Unit	24
5.6.1	High-pressure Filter (Option)	24
6	ASSEMBLY AND COMMISSIONING	25

6.1	Training of Assembly/Commissioning Staff	25
6.2	Storage conditions	25
6.3	Installation conditions	25
6.4	Transportation	25
6.5	Assembly and installation	26
6.5.1	Ventilation of the spray booth	27
6.5.2	Air supply lines	27
6.5.3	Product supply lines	27
6.6	Grounding	27
6.7	Commissioning	29
7	OPERATION	30
7.1	Training the operating staff	30
7.2	EMERGENCY STOP	30
7.3	Work	31
7.4	Pressure Relief/Work Interruption	31
7.5	Basic cleaning	32
7.5.1	Filling with working material	32
8	CLEANING AND MAINTENANCE	33
8.1	Cleaning	33
8.1.1	Cleaning staff	33
8.1.2	Decommissioning and Cleaning	33
8.1.3	Long-term storage	33
8.2	Maintenance	34
8.2.1	Maintenance staff	34
8.2.2	Maintenance Instructions	34
8.2.3	Safety checks and maintenance intervals	35
8.2.4	Emptying pump	36
8.2.5	Filling the empty pump	37
8.2.6	Cleaning and Replacing the Filter	38
8.2.7	Maintenance Hydraulic Stage	40
8.2.8	Checking the Oil Level	40
8.2.9	Oil change	41
9	TROUBLESHOOTING AND RECTIFICATION	44
10	REPAIR WORK	45
10.1	Repair Staff	45
10.2	Repair Notes	45
10.3	Tools	45
10.4	Cleaning the parts after disassembly	46
10.5	Assembly of the Device	46
11	FUNCTION TEST AFTER THE REPAIR	47
12	DISPOSAL	48
13	ACCESSORIES	50
13.1	Cobra 40-10 Accessories	50
13.2	Cobra 40-25 Accessories	52
14	SPARE PARTS	54
14.1	How can spare parts be ordered?	54
14.2	Overview of the Cobra 40-10 Components	55
14.3	Cobra 40-10 Air Motor	56

14.4	Cobra 40-10 Fluid Section	58
14.5	Overview of the Cobra 40-25 Components	61
14.6	Cobra 40-25 Air Motor	62
14.7	Cobra 40-25	64
14.8	Cobra 40-10 Inlet Valve	67
14.9	Inlet Valve Depressor	67
14.10	Cobra 40-25 Inlet Valve	68
14.11	Relief valve	68
14.12	High-pressure Filter (up to 530 bar; 7687 psi)	70
14.13	Inline Filter 90° (up to 270 bar; 3916 psi)	72
14.14	Straight Inline Filter (up to 270 bar; 3,916 psi)	73
14.15	AirCoat Regulator and AirCoat Filter Regulator	74
14.16	Cobra 40-10 Frame, Complete	75
14.17	Cobra 40-25 Frame, Complete	75
14.18	Horizontal Cobra Trolley	76
14.19	Sliding tables	78
14.20	Complete Hopper	79
14.21	2 Liter Tank	80
15	GUARANTEE AND CONFORMITY DECLARATIONS	81
15.1	Important notes on product liability	81
15.2	Warranty claim	81
15.3	EU Declaration of Conformity	82

1 ABOUT THESE INSTRUCTIONS

1.1 PREFACE

The operating manual contains information about safely operating, maintaining, cleaning and repairing the device.

The operating manual is part of the device and must be available to the operating and service personnel.

The device may only be operated by trained personnel and in compliance with this operating manual.

Operating and service personnel should be instructed according to the safety instructions. This equipment can be dangerous if it is not operated according to the instructions in this operating manual.

1.2 WARNINGS, NOTICES AND SYMBOLS IN THESE INSTRUCTIONS

Warning instructions in this operating manual highlight particular dangers to users and to the device and state measures for avoiding the hazard. These warning instructions fall into the following categories:

 **DANGER** Immediate risk of danger.
Non-observance will result in death or serious injury.

 **WARNING** Potential risk.
Non-observance can result in death or serious injury.

 **CAUTION** Potentially hazardous situation.
Non-observance may result in minor injury.

 **NOTICE** Potentially hazardous situation.
Non-observance may result in damage to property.

Notice Provides information about particular characteristics and how to proceed.

Explanation of warning:

LEVEL OF DANGER

This notice warns you of a hazard!

Possible consequences of not observing the warning instructions.

→ The measures for preventing the hazard and its consequences.



1.3 LANGUAGES

The operating manual is available in the following languages:

Original Operating Manual

Language	Order No.
German	2340850

Translation of the Original Operating Manual

Language	Order No.	Language	Order No.
French	2340852	Italian	2340853
Spanish	2340854	Russian	2345830
Japanese	2346196	Hungarian	2352542
English	2340851	--	--

Additional languages on request or at: www.wagner-group.com

1.4 ABBREVIATIONS

Order No.	Order number
ET	Spare part
K	Marking in the spare parts lists
Pos	Position

Qty	Number of pieces
DH	Double stroke
SSt	Stainless steel
2K	Two components

1.5 TERMINOLOGY FOR THE PURPOSE OF THIS MANUAL

Cleaning	
Cleaning	Manual cleaning of devices and device parts with cleaning agent.
Flushing	Internal flushing of paint-wetted parts with flushing agent.
Product pressure generator	Pump or pressure tank.
Staff qualifications	
Trained person	Is instructed in the tasks assigned to him/her, the potential risks associated with improper behavior as well as the necessary protective devices and measures.
Electrically trained person	Is instructed by an electrician about the tasks assigned to him/her, the potential risks associated with improper behavior as well as the necessary protective devices and measures.
Electrician	Can assess the work assigned to him/her and detect possible hazards based on his/her technical training, knowledge and experience in relevant provisions.
Skilled person in accordance with TRBS 1203 (2010/Revision 2012)	A person, who, based on his/her technical training, experience and recent vocational experience, has sufficient technical knowledge in the areas of explosion protection, protection from pressure hazards and electric hazards (if applicable) and is familiar with the relevant and generally accepted rules of technology so that he/she can inspect and assess the status of devices and coating systems based on workplace safety.

2 CORRECT USE

2.1 DEVICE TYPES

Double diaphragm pump and spray pack:

Cobra 40-10

Cobra 40-25

2.2 TYPE OF USE

The device is suitable for processing liquid products like paints and lacquers:

- Non-flammable products
- Products in accordance with the classification into explosion classes IIA or IIB (see Chapter [2.4](#)).

WAGNER explicitly prohibits any other use!

The device may only be operated under the following conditions:

- Use the device only to work with the products recommended by WAGNER.
- Do not deactivate safety fixtures.
- Use only WAGNER original spare parts and accessories.
- The operating personnel must be trained on the basis of this operating manual.

2.3 FOR USE IN POTENTIALLY EXPLOSIVE AREAS

The device can be employed in explosion hazard zones (Zone 1) (see Chapter [3](#)).



2.4 PROCESSIBLE WORKING MATERIALS

→ Fluid materials like paints and varnishes.

Application	Cobra 40-10	Cobra 40-25
Water-dilutable products	↗	↗
Solvent-based lacquers and paints	↗	↗
Two-component coating products	↗	↗
Emulsions	↗	↗
UV lacquers	↗	↗
Primers	→	↗
Epoxy and polyurethane lacquers, phenolic lacquers	↗	↗
Liquid plastics	→	→
Wax-based underside protection	↗	↗
Shear-sensitive lacquers	↗	↗

↗ recommended

→ limited suitability

↘ not suitable

! NOTICE**Abrasive working materials and pigments!**

Greater wear of parts carrying the product.

→ Use the application-oriented model (flow rate/cycle, product, valves, etc.) as indicated in Chapter [5.5](#).

→ Check if the fluids and solvents used are compatible with the pump construction materials as indicated in Chapter [5.5.1](#).

→ Use suitable combinations of devices (packings, valves etc.)

Wear caused by abrasive working materials is not covered by the warranty.

Typical applications

Application	Cobra 40-10	Cobra 40-25
Furniture industry	↗	↗
Kitchen manufacturers	↗	↗
Joinery	↗	↗
Window factories	→	↗
Steel-processing industry	→	→
Construction of vehicles	↗	↗
Shipbuilding	↘	↘

↗ recommended

→ limited suitability

↘ not suitable

2.5 MISUSE

Misuse can lead to physical injury and/or property damage!

Special attention must be paid that:

→ no dry coating products, e.g. powder are processed.

→ no food, medicine or cosmetics are processed.

It is important to note that the device's materials are not food-safe.

3 IDENTIFICATION

3.1 EXPLOSION PROTECTION IDENTIFICATION

As defined in the Directive 2014/34/EU (ATEX), the device is suitable for use in potentially explosive areas.

Device types: Double diaphragm pumps **Cobra 40-10** and **Cobra 40-25**
 Manufacturer: Wagner International AG
 CH-9450 Altstätten, Switzerland



CE  II 2 G Ex h IIB T6 Gb X

CE	European Communities
Ex	Symbol for explosion protection
II	Device class II
2	Category 2 (Zone 1)
G	Ex-atmosphere gas
Ex	Explosion protection
h	Ignition protection for non-electrical devices
IIB	Explosion group
T6	<85 °C
Gb	High safety level
X	Special notes (see Chapter 3.2) → See the following Chapter "Identification X".



3.2 IDENTIFICATION "X"

The maximum surface temperature corresponds to the permissible product temperature. This and the permissible ambient temperature can be found in Chapter [5.5.2](#) (Technical Data).

Safe handling of WAGNER spray devices

Mechanical sparks can form if the device comes into contact with metal.
 In an explosive atmosphere:

- Knocking or pushing metal against metal is to be avoided.
- Do not drop the device.

Maximum surface temperature

- The maximum surface temperature of the pump depends on the operating conditions (heated product) and not on the device (frictional heat).

Ignition temperature of the coating product

- Ensure that the ignition temperature of the coating product is above the maximum surface temperature.

Ambient temperature

- Permissible ambient temperature: 10 °C to 60 °C; 50 °F to 140 °F.

Medium supporting atomizing

- To atomize the product, use only weakly oxidizing gases, e.g., air.

Surface spraying, electrostatics

- Do not spray device parts using electrostatic equipment.

Cleaning

If there are deposits on the surfaces, the device may form electrostatic charges. Flames or sparks can form during discharge.

- Remove deposits from the surfaces to maintain conductivity.
- Use only a damp cloth to clean the device.



Air in the pump fluid

Flammable gas mixtures can form if air reaches the pump fluid.

- Prevent the pump from taking in air and running dry.
- If air has been taken in, fix the leak. Then, fill slowly and in a controlled manner until the air has escaped.

Air in the pumped fluid can be caused by damaged diaphragms.

- Avoid operating the pump with damaged diaphragms.
- Periodically check that the pump is working smoothly, paying special attention to the presence of air in the pumped fluid.

Filling and emptying

Flammable gas mixtures can form in the fluid section or product hoses if the pump must be emptied for maintenance.

- Empty and fill the device slowly and in a controlled manner.
- Avoid potentially explosive atmosphere in the surroundings.



3.3 TYPE PLATES**Example for Cobra 40-10**

 Wagner International AG CH-9450 Altstätten Made in Switzerland		  II 2G Ex h IIB T6 Gb X	
1	Pumpentyp/ Pump type/ Type de pompe	40-10	
2	Max. Materialdruck/ Fluid pressure/ Pression fluid	25 MPa	
3	Übersetzungsverhältnis/ Ratio/ Rapport	40:1	
4	Fördermenge DH/ Delivery DS/ Débit CD	10 ccm	
5	Max. Luftdruck/ Air pressure/ Pression d'air	0.6 MPa	
6	Max. Temp. Material/ Fluid	80°C	
7	Baujahr - Serie Nr. / Year of manufacture - Serial No.	2017-3001	
8	Vor Gebrauch Betriebsanleitung beachten / Check manual before use!		

B_05038

Pos	Designation
1	Pump type
2	Max. product pressure
3	Pump ratio
4	Delivery rate
5	Max. air pressure
6	Max. temp. product/ fluid
7	Model year - serial number
8	Read the operating manual before use

Example for Cobra 40-25

 Wagner International AG CH-9450 Altstätten Made in Switzerland		  II 2G Ex h IIB T6 Gb X	
1	Pumpentyp/ Pump type/ Type de pompe	40-25	
2	Max. Materialdruck/ Fluid pressure/ Pression fluid	25 MPa	
3	Übersetzungsverhältnis/ Ratio/ Rapport	40:1	
4	Fördermenge DH/ Delivery DS/ Débit CD	25 ccm	
5	Max. Luftdruck/ Air pressure/ Pression d'air	0.63 MPa	
6	Max. Temp. Material/ Fluid	80°C	
7	Baujahr - Serie Nr. / Year of manufacture - Serial No.	2017-3001	
8	Vor Gebrauch Betriebsanleitung beachten / Check manual before use!		

B_05039

4 BASIC SAFETY INSTRUCTIONS

4.1 SAFETY INSTRUCTIONS FOR THE OPERATOR

- Keep this operating manual at hand near the device at all times.
- Always follow local regulations concerning occupational safety and accident prevention.



4.1.1 ELECTRICAL DEVICES AND EQUIPMENT

Electric shock hazard!

Danger to life from electric shock

- Prepare device in accordance with the local safety requirements with regard to the operating mode and ambient influences.
- May only be maintained by skilled electricians or under their supervision. With open housings, there is a danger from line voltage.
- Operate device in accordance with the safety regulations and electrotechnical regulations.
- Must be repaired immediately in the event of problems.
- Decommission if it poses a hazard or is damaged.
- Must be de-energized before work is commenced. Inform staff about planned work. Observe electrical safety regulations.
- Ground all devices to a common grounding point.
- Only operate the device with a properly installed socket with a protective ground wire connection.
- Keep liquids away from electrical devices.



4.1.2 A SAFE WORK ENVIRONMENT

Hazard due to dangerous fluids or steam!

Severe or fatal injuries due to explosion hazard or inhalation, swallowing or contact with the skin or eyes.

- Ensure that the floor in the working area is static dissipative in accordance with EN 61340-4-1 (resistance must not exceed 100 MΩ).
- Paint mist extraction systems/ventilation systems must be fitted on site according to local regulations.
- Make sure that the ground connection and potential equalization of all system parts are reliable and continuous and can withstand the expected stress (e.g. mechanical stress, corrosion).
- Ensure that product / air hoses adapted to the working pressure are used.
- Ensure that personal protective equipment (see Chapter 4.2.1) is available and is used.
- Ensure that all persons within the working area wear static dissipative shoes. Footwear must comply with EN 20344. The measured insulation resistance must not exceed 100 MΩ.
- Ensure that during spraying, persons wear electrically conductive gloves. The grounding takes place via the spray gun handle or the trigger.
- Protective clothing, including gloves, must comply with EN 1149-5. The measured insulation resistance must not exceed 100 MΩ.
- Ensure that there are no ignition sources such as naked flames, sparks, glowing wires, or hot surfaces in the vicinity. No smoking.



- Ensure that the pipe joints, hoses, equipment parts and connections are permanently, technically leak-proof:
 - Periodic preventative maintenance and service (replacing hoses, checking tightness strength of the connections etc.).
 - Regular monitoring of leaks and defects via visual inspection and odor testing, e.g., daily before commissioning, at the end of work or weekly.
- Ensure that maintenance and safety checks are performed regularly.
- In the event of defects, immediately bring the device or system to a stop and arrange to have repairs carried out immediately.

4.1.3 PERSONNEL QUALIFICATIONS

Hazard due to incorrect use of device!

Risk of death due to untrained personnel.

- Ensure that the operating personnel has been instructed by the operator in accordance with the operating manual and the operating instructions. The device must only be operated, maintained and repaired by trained personnel. Refer to the operating instructions for information about the required personnel qualifications.

4.2 SAFETY INSTRUCTIONS FOR STAFF

- Always follow the information in this manual, particularly the safety instructions and the warning instructions.
- Always follow local regulations concerning occupational safety and accident prevention.
- In electrostatics applications: anyone who belongs to a risk group according to EMF Directive 2013/35/EU (e.g. those with active implants), must not enter the high-voltage area.



4.2.1 PERSONAL SAFETY EQUIPMENT

Hazard due to dangerous fluids or steam!

Serious or fatal injuries due to inhalation, swallowing or contact with the skin or eyes.

- When preparing or working with paint and when cleaning the device, follow the working instructions of the manufacturer of the lacquers, solvents, and cleaning agents being used.
- Take the specified protective measures. In particular wear safety goggles, protective clothing and gloves, as well as hand protection cream if necessary.
- Use a mask or breathing apparatus if necessary.
- For sufficient health and environmental safety: Operate the device in a spray booth or on a spraying wall with the ventilation (extraction) switched on.
- Wear suitable protective clothing when working with hot products.



4.2.2 SAFE HANDLING OF WAGNER SPRAY DEVICES**Hazard due to injection of lacquer or flushing agent into the skin!**

The spray jet is under pressure and can cause dangerous injuries. Avoid injection of paint or flushing agents:

- Never point the spray gun at people.
- Never reach into the spray jet.
- Before any work on the device, in the event of work interruptions and malfunctions:
 - Switch off the energy/compressed air supply.
 - Relieve the pressure from the spray gun and device.
 - Secure the spray gun against actuation.
 - Disconnect the control unit from the mains.
 - In the event of functional faults, remedy the fault as described in the "Troubleshooting" chapter.
- If necessary or at least every 12 months, the liquid ejection devices must be checked for safe working conditions by an expert (e.g. WAGNER Service Technician) in accordance with the guidelines for liquid ejection devices (ZH 1/406 and DGUV 100-500 Chapters 2.29 and 2.36).
 - For shut-down devices, the check can be postponed until the next start-up.

**In the event of skin injuries caused by lacquer or flushing agents:**

- Note the lacquer or flushing agent that you have been using.
- Consult a doctor immediately.

Danger due to recoil forces!

Actuating the trigger can cause strong recoil forces. Thereby the user can lose his balance and injure himself during falling.

Avoid risk of injury from recoil forces:

- Ensure that you have firm footing when operating the spray gun.

**4.2.3 GROUND THE UNIT****Hazard due to electrostatic charge!**

Explosion hazard and damage to the device.

Friction, flowing liquids and air or electrostatic coating processes create charges. Flames or sparks can form during discharge.

Correct grounding of the entire spraying system prevents electrostatic charges.

- Ensure that all devices and tanks are grounded before each spraying process.
- Ground the work pieces to be coated.
- Ensure that all persons inside the working area are grounded, e.g., that they are wearing static dissipative shoes.
- Wear static dissipative gloves when spraying. The grounding takes place via the spray gun handle or the trigger.



4.2.4 PRODUCT HOSE

Hazard due to bursting of product hose!

The product hose is under pressure and may cause dangerous injuries.

- Ensure that the hose material is chemically resistant to the sprayed products and the flushing agents used.
- Ensure that the product hose and the fittings are suitable for the pressure generated.
- Ensure that the following information can be seen on the high-pressure hose:
 - manufacturer
 - permissible operating pressure
 - date of manufacture

- Make sure that the hoses are laid only in suitable places. Hoses should not be laid in the following places under any circumstances:
 - in high traffic areas
 - on sharp edges
 - on moving parts or
 - on hot surfaces
- Ensure that the hoses are never run over by vehicles (e.g., fork lift trucks), or that the hoses are never put under pressure from the outside in any other way.

- Ensure that the hoses are never kinked. Observe maximum bending radii.

- Ensure that no work is ever performed with a damaged hose.
- Make sure that the hoses are never used to pull or move the equipment.

- The electrical resistance of the product hose, measured at both valves, must be less than 1 MΩ.
- Suction hoses may not be subjected to pressure.



Several liquids have a high expansion coefficient. In some cases their volume can rise with consequent damage to pipes, fittings, etc. and cause fluid leakage.

When the pump sucks liquid from a closed tank, ensure that air or a suitable gas can enter the tank. Thus a negative pressure is avoided. The vacuum could implode the tank (squeeze) and can cause it to break. The tank would leak and the liquid would flow out.

The pressure created by the pump is a multiplication of the inlet air pressure.

4.2.5 CLEANING AND FLUSHING

Hazard due to cleaning and flushing!

Explosion hazard and damage to the device.

- Preference should be given to non-flammable cleaning and flushing agents.
- When carrying out cleaning work with flammable cleaning agents, make sure that all equipment and resources (e.g., collection tank, funnel, transport cart) are conductive or static dissipative and grounded.
- Observe the specifications of the lacquer manufacturer.
- Ensure that the flash point of the cleaning agent is at least 15 K above the ambient temperature or that cleaning is undertaken at a cleaning station with technical ventilation.
- Never use chloride or halogenated solvents (such as trichloroethane and methylene chloride) with units containing aluminium or galvanized and zinc-plated parts. They may react chemically thus producing an explosion danger.
- Take measures for workplace safety (see Chapter [4.1.2](#)).
- When commissioning or emptying the device, please note that an explosive mixture may temporarily exist inside the lines and components of equipment:
 - depending upon the used coating product,
 - depending on the flushing agent (solvent) used.
 explosive mixture inside the lines and items of equipment.
- Only electrically conductive tanks may be used for cleaning and flushing agents.
- The tanks must be grounded.



An explosive gas/air mixture forms in closed tanks.

- Never spray into a closed tank when using solvents for flushing.

External cleaning

When cleaning the exterior of the device or its parts, also observe the following:

- Relieve the pressure from the device.
- De-energize the device electrically.
- Disconnect the pneumatic supply line.
- Use only moistened cloths and brushes. Never use abrasive agents or hard objects, and never spray cleaning agents with a spray gun. Cleaning the device must not damage it in any way.
- Ensure that no electric component is cleaned with or immersed into solvent.

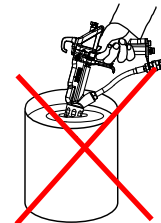

4.2.6 TOUCHING HOT SURFACES

Hazard due to hot surfaces because of hot coating products!

Risk of burn injuries

- Only touch hot surfaces if you are wearing protective gloves.
- When operating the device with a coating product with a temperature of > 43 °C; 109 °F:
 - Identify the device with a warning label "Warning – hot surface".

Order No.

9998910 Instruction label

9998911 Protection label

Note: Order the two stickers together.



4.2.7 MAINTENANCE AND REPAIR

Hazard due to improper maintenance and repair!

Danger to life and equipment damage.

- Only a WAGNER service center or a suitably trained person may carry out repairs and replace parts.
- Use only WAGNER original spare parts and accessories.
- Do not change or modify the device; if change is necessary, contact WAGNER.
- Only repair and replace parts that are listed in the [13](#) "Spare parts" chapter and [14](#) that are assigned to the unit.
- Do not use any defective components.
- Exclusively use accessories listed in Chapter [13](#) and that are assigned to the unit.
- Before all work on the device and in the event of work interruptions:
 - Relieve the pressure from the spray gun, high-pressure hoses and all devices.
 - Secure the spray gun against actuation.
 - Switch off the energy and compressed air supply.
 - Disconnect the control unit from the mains. Secure the spray gun against actuation.
- Observe the operating and service manual for all work.

4.2.8 PROTECTIVE AND MONITORING EQUIPMENT

Hazard due to removal of protective and monitoring equipment!

Danger to life and equipment damage.

- Protective and monitoring equipment must not be removed, modified or rendered unusable.
- Regularly check for perfect functioning.
- If defects are detected on protective and monitoring equipment, the system must not be operated until these defects are remedied.

5 DESCRIPTION

5.1 COMPONENTS

Pos	Designation
1	Control housing with integrated silencer
2	Air pressure regulator
3	Ball valve
4	Air motor
5	Compressed air Inlet
6	Mounting flange
7	Relief valve
8	Product outlet
9	Fluid section
10	Product inlet
11	Grounding connection
12	Pressure stage casing
13	Return socket
14	Valve depressor
15	Exhaust air cap

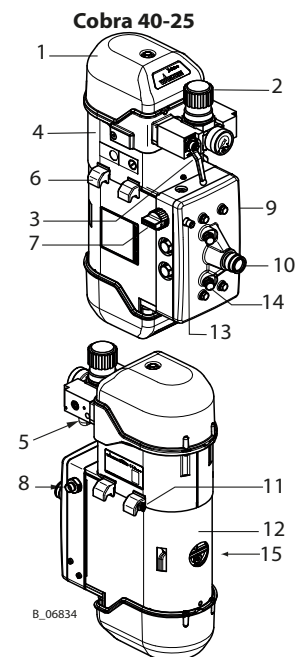
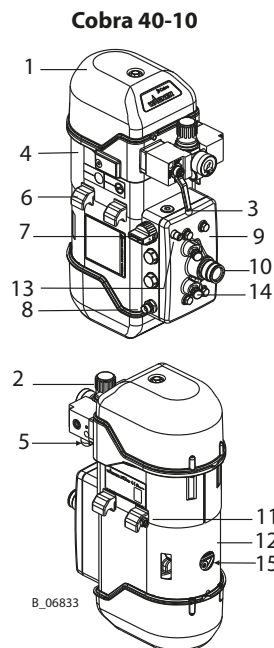

5.2 MODE OF OPERATION

The double diaphragm pump is driven with compressed air. This compressed air moves the air piston in the air motor (4), and consequently the piston rod in the pressure stage (9), up and down. At the end of each stroke the compressed air is redirected by a reversing valve and the control piston. The up-and-down movement of both diaphragms within the fluid section is produced by hydraulic oil, which is moved by the piston in the pressure stage. With every stroke of the piston rod, working material is sucked in and delivered to the spray gun at the same time.

5.2.1 AIR MOTOR

The air motor with its pneumatic reverse (1) does not require pneumatic oil. The compressed air is fed to the motor via the air pressure regulator (2) and the ball valve (3).

5.2.2 FLUID SECTION

The fluid section has been designed as a double diaphragm pump with exchangeable inlet and outlet valves. Change between "spraying mode" and "circulation mode" using the relief valve (7).

5.3 PROTECTIVE AND MONITORING EQUIPMENT

WARNING

Overpressure!

Danger to life from bursting components.

→ Never change the safety valve setting.



The air motor is fitted with a safety valve. The safety valve has been set and sealed at the factory. In case of pressures over and above the permissible operating pressure, the valve, which is held with a spring, automatically opens and releases the excess pressure.

5.4 INCLUDED ITEMS

Stk	Order No.	Designation
1	2329519	Diaphragm pump Cobra 40-10 consisting of: Fluid section, air motor, connection elements
1	2329521	Frame-mounted diaphragm pump Cobra 40-10 consisting of: Fluid section, air motor, connection elements
1	2329523	Diaphragm pump Cobra 40-25 consisting of: Fluid section, air motor, connection elements
1	2329525	Frame-mounted diaphragm pump Cobra 40-25 consisting of: Fluid section, air motor, connection elements

The standard equipment includes:

Stk	Order No.	Designation
1	322981	Sign
1	236219	Grounding cable, complete
1	341434	Double open-end wrench
1	see Chapter 15.2	Declaration of Conformity
1	2340850	Operating manual, German
1	see Chapter 1.3	Operating manual in the local language

The delivery note shows the exact scope of delivery. Accessories: see Chapter [13](#).

5.5 DATA

5.5.1 MATERIALS OF PAINT WETTED PARTS

Paint-wetted parts	Product
Inlet housing	Consital® (aluminum alloy)
Fluid section	Consital® (aluminum alloy)
Valve balls	Stainless steel
Valve seats/valve cone	Carbide
Diaphragms	Resistant PA
Valve fitting	1.4104

5.5.2 TECHNICAL DATA

Description	Units	Cobra 40-10	Cobra 40-25
Pump ratio		40:1	40:1
Volume flow per double stroke (DH)	cm ³	10	25
	cu inch	0.6	1.5
Maximum operating overpressure	MPa	25	25
	bar	250	250
	psi	3626	3626
Maximum possible strokes in operation	DH/min	200	200
Minimum/maximum air inlet pressure	MPa	0.25–0.6	0.25–0.6
	bar	2.5–6	2.5–6
	psi	36.3–87	36.3–87
Compressed air quality: free from oil and water	Quality standard 7.5.4 according to ISO 8573.1, 2010		
		7: Particle concentration 5 – 10 mg/m ³	
		5: Humidity: pressure dew point ≤ 7 °C	
		4: Oil content ≤ 5 mg/m ³	
∅ Air inlet (inside thread)	inch	G 1/2"	G 1/2"
Minimum ∅ of the compressed air supply line	mm	13	19
	inch	0.51	0.75
Air consumption at 0.6 MPa; 6 bar; 87 psi per double stroke	NL	3.5	8.3
Sound pressure level at maximum permissible air pressure*	dB(A)	74	76
Sound pressure level at 0.45 MPa; 4.5 bar; 65.27 psi air pressure*	dB(A)	72	74
Sound pressure level at 0.3 MPa; 3 bar; 43.5 psi air pressure*	dB(A)	69	71
Air motor piston diameter	mm	80	100
	inch	3.15	4
Product inlet (outside thread)	mm	M36×2	M36×2
Product outlet (inside thread)	inch	G 3/8"	G 3/8"
Product outlet (outside thread)	inch	G 3/8"	G 3/8"
Weight	kg; lb	19; 41.9	33; 72.8
Product pH value	pH	3.5–9	3.5–9
Maximum product pressure at pump inlet	MPa	2	2
	bar	20	20
	psi	290	290
Product temperature	°C	10–80	10–80
	°F	50–176	50–176
Ambient temperature	°C	10–60	10–60
	°F	50–140	50–140
Allowable inclination for operation	∠°	±10	±10
Hydraulic oil filling amount (approximate)	L	0.110	0.130
	cu inch	6.71	7.93

*A-rated sound pressure level measured at 1 m distance, LpA1m, according to DIN EN 14462: 2015. Reference measurements have been made by SUVA (Swiss Accident Insurance Institute).

⚠ WARNING**Exhaust air containing oil!**

Risk of poisoning if inhaled.

→ Provide compressed air free from oil and water.





5.5.3 DIMENSIONS AND CONNECTIONS

Pos	Cobra 40-10 mm; inch	Cobra 40-25 mm; inch
A	505; 19.88	605; 23.82
B	313; 12.32	379; 14.92
C	322; 12.68	373; 14.69
D	134; 5.28	
E	55; 2.16	
F	182; 7.16	
G	80; 3.15	
H	M6	
I	ø 25; ø 0.98	
K	G1/4"	
L	M36x2	
M	G 3/8"A	
N	149; 5.87	
O	91; 3.58	
P	107; 4.21	
Q	175; 6.89	
R	ø 7; ø 0.28	
S	525; 20.67	644; 25.35
T	367; 14.45	417; 16.42
U	275; 10.83	

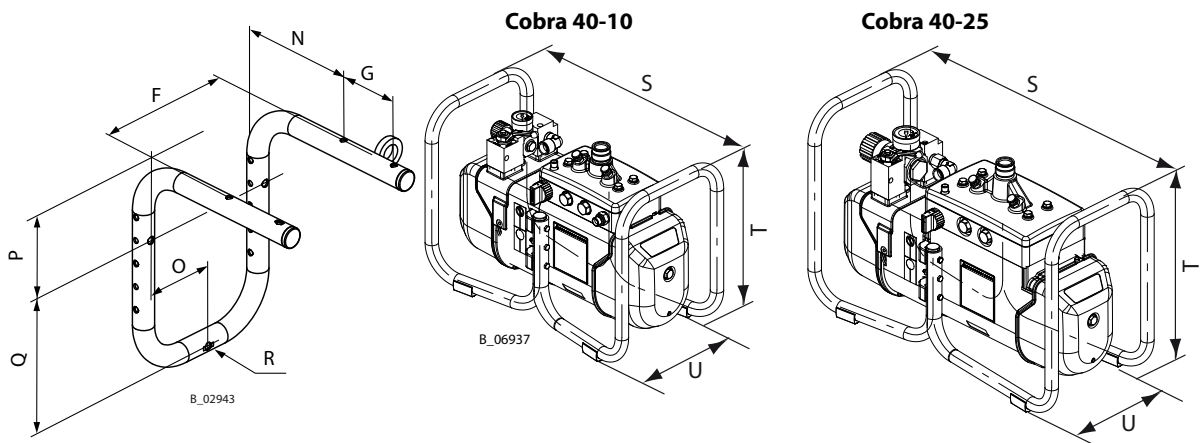
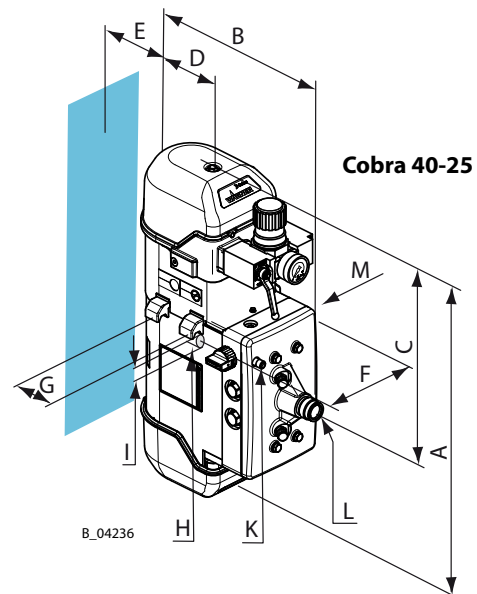
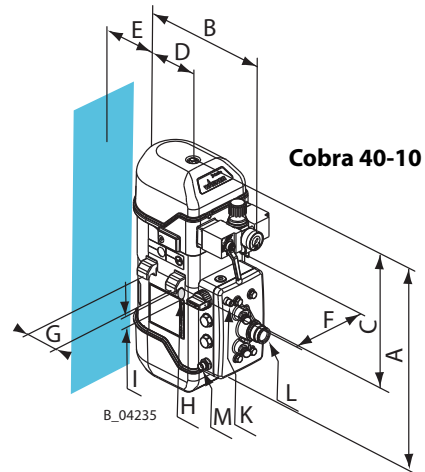

5.5.4 VOLUME FLOW

Wagner AL nozzles			Volume flow in l/min.*		
ø inch	ø mm	Spray angle	at	at	at
			7 MPa	10 MPa	15 MPa
			70 bar	100 bar	150 bar
			1015 psi	1450 psi	2175 psi
0.007	0.18	40°	0.1650	0.2000	0.2400
0.009	0.23	20-30-40-50-60°	0.2060	0.2500	0.3090
0.011	0.28	10-20-30-40-50-60°	0.2950	0.3450	0.4260
0.013	0.33	10-20-30-40-50-60-80°	0.4530	0.5280	0.6600
0.015	0.38	10-20-30-40-50-60-80°	0.5770	0.6720	0.8130
0.017	0.43	20-30-40-50-60-70°	0.7310	0.7860	1.0640
0.019	0.48	20-30-40-50-60-70-80°	0.9260	1.0920	1.3700
0.021	0.53	20-40-50-60-80°	1.1430	1.3600	1.6900
0.023	0.58	20-40-50-60-70-80°	1.3700	1.5900	2.0100
0.025	0.64	20-40-50-60-80°	1.6200	1.9100	2.4000
0.027	0.69	20-40-50-60-80°	1.8300	2.1300	2.6800
0.029	0.75	60°	2.1900	2.5100	3.1700
0.031	0.79	20-40-50-60°	2.4000	2.7700	3.4900
0.035	0.90	20-40-50-60°	3.2200	3.7400	4.6900
0.043	1.10	20-50°	5.0700	6.0400	7.4600
0.052	1.30	50°	5.1200	6.5000	7.5200

Cobra 40-10

Cobra 40-25

* Volume flow refers to water.

– Maximum ranges for continuous operation at 200 DH/min.



5.5.5 PERFORMANCE DIAGRAMS

Example

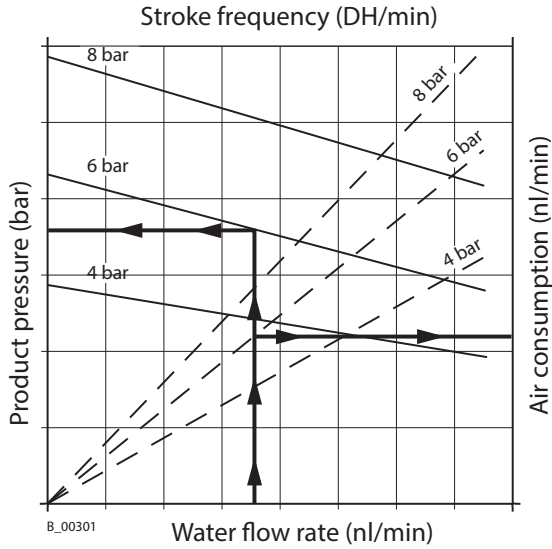

Cobra 40-10

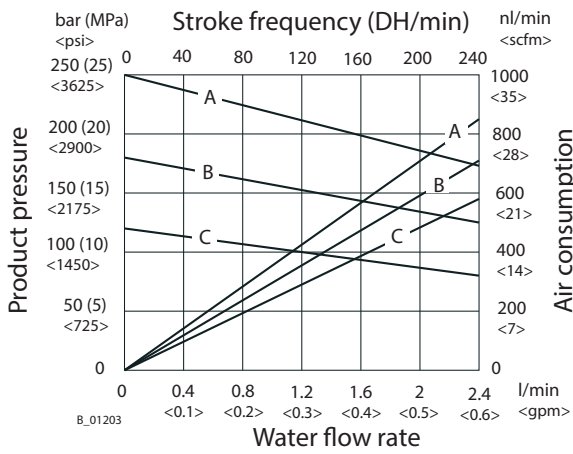

A = 6 bar (0.6 MPa; 87 psi) air pressure
 B = 4.5 bar (0.45 MPa; 65 psi) air pressure
 C = 3 bar (0.3 MPa; 44 psi) air pressure

Cobra 40-25

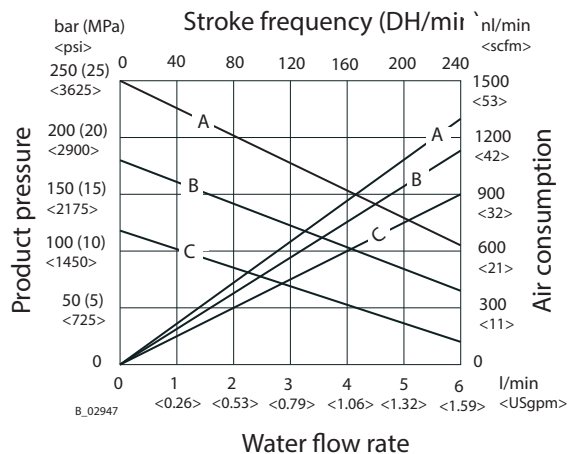

A = 6 bar (0.6 MPa; 87 psi) air pressure
 B = 4.5 bar (0.45 MPa; 65 psi) air pressure
 C = 3 bar (0.3 MPa; 44 psi) air pressure

5.6 COBRA PRESSURE REGULATOR UNIT

Pos	Designation
1	Pressure regulator
2	Ball valve
3	Pressure gauge
4	Compressed air Inlet
5	AirCoat filter regulator Cobra (accessories)

The AirCoat filter regulator must be mounted vertically in all installation positions for the diaphragm pump (see assembly manual for Filter Regulator, order number 2328614).

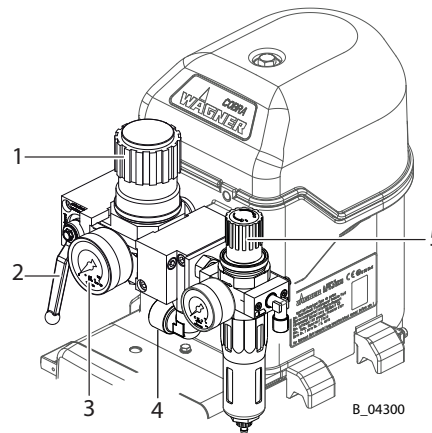

Pos	Positions of the ball valve
1	Open: working position
2	Closed: the air motor can still be under pressure.
3	Vent: Operating pressure in the air motor is vented (control pressure is still present).

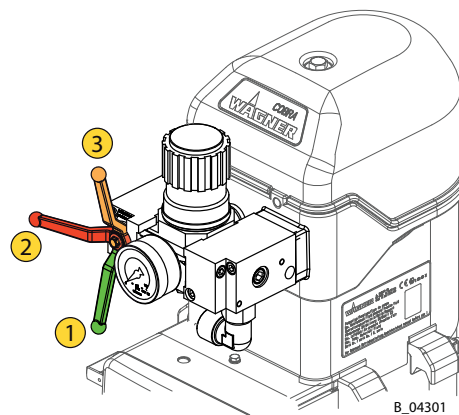

5.6.1 HIGH-PRESSURE FILTER (OPTION)

To ensure problem-free operation it is recommended that a WAGNER high-pressure filter be used. These have been developed especially for WAGNER pneumatic pumps. The filter inserts can be exchanged depending on the product to be used. The high-pressure filter corresponding to the device can be found in Chapter; [13](#) and the compatible filter inserts can be found in Chapter [14](#)

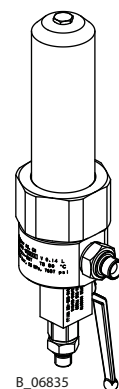

6 ASSEMBLY AND COMMISSIONING

6.1 TRAINING OF ASSEMBLY/COMMISSIONING STAFF

- The assembly and commissioning staff must have the technical skills to safely commission the device.
- When assembling, commissioning and carrying out all work, read and follow the operating manuals and safety regulations for the additionally required system components.

A skilled person must check to ensure that the device is in a reliable state after it is installed and commissioned.

6.2 STORAGE CONDITIONS

Until the point of assembly, the device must be stored in a dry location, free from vibrations and with a minimum of dust. The device must be stored in closed rooms.

The air temperature at the storage location must be between -20 °C and 60 °C (-4 °F and 140 °F).

The relative air humidity at the storage location must be between 10 and 95% (without condensation).

6.3 INSTALLATION CONDITIONS

The air temperature at the installation site must be in a range between 0 °C and 40 °C; 32 °F and 132 °F.

The relative air humidity at the installation site must be between 10 and 95% (without condensation).

6.4 TRANSPORTATION

The pump can be moved on a trolley or manually without lifting equipment.

6.5 ASSEMBLY AND INSTALLATION

WARNING

Inclined ground!

Risk of accidents if the device rolls away/falls.

- Position the trolley with the double diaphragm pump horizontally.
- If the surface is inclined, position the feet of the trolley towards the gradient.
- Secure the trolley.



National regulations

- Ensure that the national explosion prevention rules and regulations are observed when setting up the device.

Positioning

The Cobra pump may only be operated in a horizontal or vertical position as shown in the diagrams. Overhead operation is not permitted.

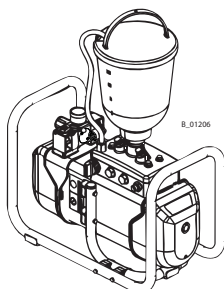

Horizontal positioning

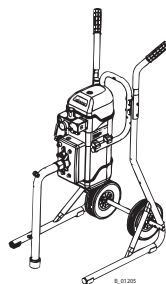

Vertical positioning

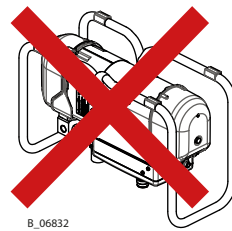

Overhead positioning

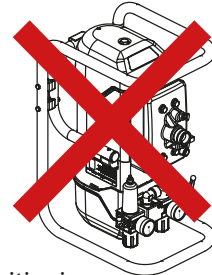

This pump can be used as part of a spraying system for Airless or AirCoat applications. The components can be found in the accessories list, provided that the system was not obtained as a spray pack. The nozzles must be selected according to the spray gun instructions.

Procedure

1. Mount the pump on a frame, trolley (6), or wall mount.
2. For AirCoat systems: Mount the additional filter pressure regulator (7) (option).
3. Mount suction system (5).
4. Mount return hose (4) (option).
5. Connect high-pressure hose and spray gun (2) according to the operating manual.

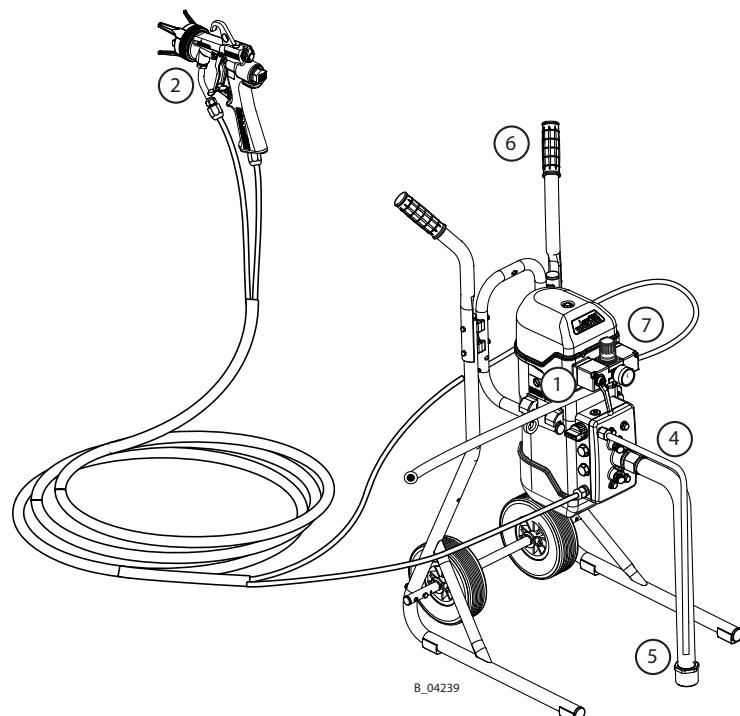

6.5.1 VENTILATION OF THE SPRAY BOOTH

- Operate the device in a spray booth approved for the working materials.
 - or -
- Operate the device on an appropriate spraying wall with the ventilation (extraction) switched on.
- Observe national and local regulations for the exhaust air speed.

6.5.2 AIR SUPPLY LINES

Ensure that only dry, clean atomizing air is used in the spray gun! Dirt and moisture in the atomizing air worsens the spraying quality and spray pattern.

⚠ WARNING**Hose connections!**

Risk of injury and damage to the device.

- Do not mix up hose connections of product hose and air hose.

**6.5.3 PRODUCT SUPPLY LINES****⚠ DANGER****Bursting hose, bursting threaded joints!**

Danger to life from injection of product.

- Ensure that the hose material is chemically resistant to the sprayed products.
- Ensure that the spray gun, fittings and product hose between the device and the spray gun are suitable for the pressure generated in the device.
- Ensure that the following information can be seen on the high-pressure hose:
 - Manufacturer
 - Permissible operating pressure
 - Date of manufacture

**6.6 GROUNDING****⚠ WARNING****Discharge of electrostatically charged components in atmospheres containing solvents!**

Explosion hazard from electrostatic sparks.

- Clean the pump only with a damp cloth.

**⚠ WARNING****Heavy paint mist if grounding is insufficient!**

Danger of poisoning.

Insufficient paint application quality.

- Ground all device components.
- Ground the work pieces to be coated.



Grounding scheme (example)

Pos	Designation
1	Conveyor
2	Work piece
3	Pump
4	Paint tank
5	Spraying stand
6	Floor, static dissipative

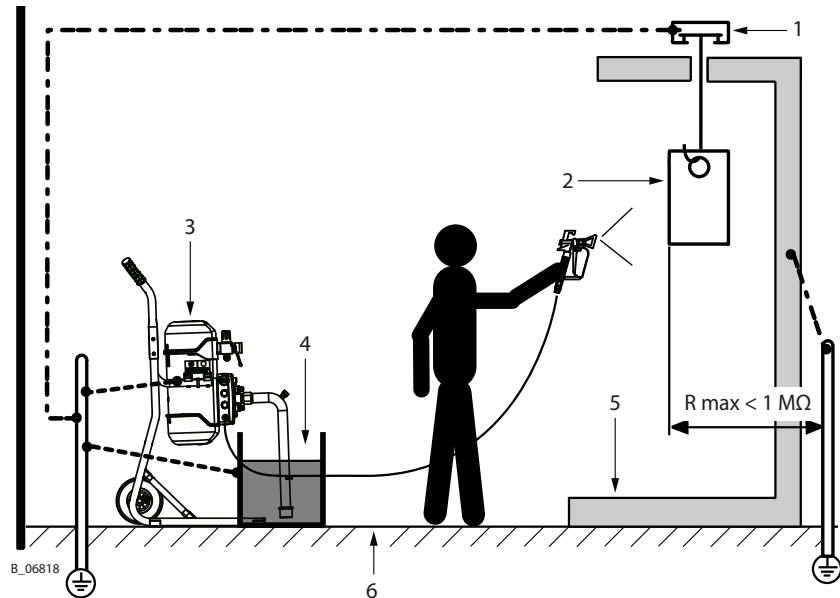

Part / workstation	Cable cross section
Pump	4 mm ² ; AWG 12
Paint tank	6 mm ² ; AWG 10
Conveyor	16 mm ² ; AWG 6
Booth	16 mm ² ; AWG 6
Spraying stand	16 mm ² ; AWG 6

Safe operation of the Cobra pump is only guaranteed with a grounding connection. Connect all ground cables using a short and direct route.

Procedure

1. Screw on grounding cable with eye.
2. Clamp the grounding cable clip to a grounding connection on site.
3. Ground the product (paint) tank to an on-site grounding connection.
4. Ground the other parts of the system to an on-site grounding connection.

Ex zone

All devices and equipment must be suitable for use in potentially explosive areas.

- All paints, flushing agents and waste tanks have to be electrically conductive.
- All tanks must be grounded.

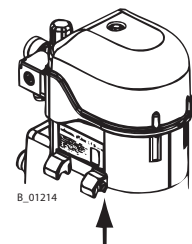

6.7 COMMISSIONING**⚠ WARNING****Gas mixtures can explode if there is an incompletely filled pump!**

Danger to life from flying parts.

- Ensure that the pump and suction system are always completely filled with flushing agent or working medium.
- Do not spray the device empty after cleaning.

**⚠ NOTICE****Impurities in the spraying system!**

Spray gun blockage.

- Flush the spray gun and paint supply with a suitable flushing agent before commissioning.

- Emergency stop, see Chapter [7.2](#).

Preparation

Before every start-up, the following points should be observed as laid down in the operating manual:

- Secure spray gun with safety lever.
- Check the permissible pressures.
- Check all connections for leaks.
- Check hoses for damage in accordance with Chapter [8.2.3](#).

Fill the pump with flushing agent

The devices are tested during manufacturing with emulsifying oil, pure oil or solvent.

Possible residues must be flushed out of the circuits with a solvent (flushing agent) before commissioning.

- Fill the empty device with flushing agent in accordance with Chapter [8.2.5](#).

Pressure tightness test**⚠ WARNING****Overpressure!**

Risk of injury from bursting components.

- The operating pressure must not exceed the value shown on the type plate.



- Gradually increase the pressure in pump with the pressure regulator until maximum pressure is reached. Maintain the pressure for 3 minutes and check all connection points for leaks.
- Depressurization in accordance with Chapter [7.4](#).

Verifying a Safe Operational Condition

A skilled person must check to ensure that the device is in a reliable state after it is installed and commissioned.

This includes:

- Carry out safety checks in accordance with Chapter [8.2.3](#).

**Filling with working material**

- According to Chapter [8.2.5](#).

7 OPERATION

7.1 TRAINING THE OPERATING STAFF

- The operating staff must be qualified to operate the entire system.
- The operating staff must be familiar with the potential risks associated with improper behavior as well as the necessary protective devices and measures.
- Before work commences, the operating staff must receive appropriate system training.

7.2 EMERGENCY STOP

In the case of unforeseen occurrences:

- Set ball valve (1) to vent.
- Open relief valve (2).

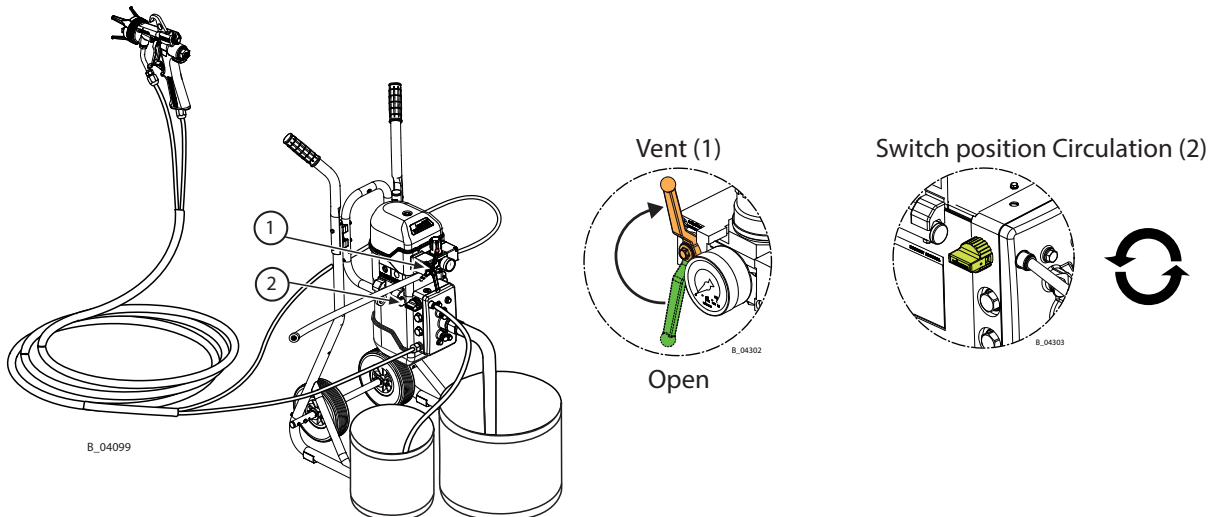

7.3 WORK

Ensure that:

→ commissioning is carried out in accordance with Chapter 6.7.

Pos	Ball valve position
1	To: working position
2	Closed: the air motor can still be under pressure.
3	Vent: Operating pressure in the air motor is vented (control pressure is still present).

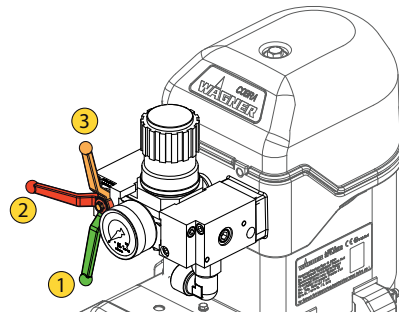

1. Visual check:
personal safety equipment, grounding and all devices ready to use.
2. Secure spray gun and insert valve into the spray gun.
3. Slowly open the ball valve.
4. Set the required working pressure on the pressure regulator.
5. Optimize the spray pattern as laid down in the spray gun instructions.
6. Start work process.

Note: Depending on the function, the pump may continue running for 1 - 6 DH/min. after the spray gun is closed.

7.4 PRESSURE RELIEF/WORK INTERRUPTION

The pressure must always be relieved when:

- after the spraying tasks are finished.
- Before servicing the system.
- before carrying out cleaning tasks on the system.
- before moving the system to another location.
- before something needs to be checked on the system.
- before the nozzle is removed from the spray gun.

Process for relieving pressure

1. Close the spray gun.
2. Close ball valve.
3. Vent air motor.
4. Release the system of pressure by opening the spray gun.
5. Close and secure the spray gun.

Note:

Control air pressure is still present.

If the system has been used with 2K products:

⚠ NOTICE

Hardened working material in the spraying system when 2K product is processed!

Destruction of pump and injection system.

- Follow the manufacturer's processing rules, particularly regarding the pot life.
- Flush thoroughly before the end of the pot life.
- The pot life is decreased by warmth.

7.5 BASIC CLEANING

Flush regularly

- Regular flushing, cleaning and maintenance ensures the pumps' high pumping and suction capacity.
- The cleaning and flushing agents used must be compatible with the working material.

WARNING

Incompatibility of flushing / cleaning agent with the working medium!

Risk of explosion and danger of poisoning by toxic gases.

- Examine the compatibility of the flushing and cleaning agents and working media on the basis of the safety data sheets.



Procedure

1. Visual check: personal safety equipment, grounding and all devices ready to use.
2. Place empty tank (5) under return tube (4).
3. Place suction hose (7) in a tank with cleaning agent (6).
4. Adjust the pressure regulator (1) to approx. 0.05 MPa; 0.5 bar; 7.25 psi.

Flushing via return tube

5. Open relief valve (3).
6. Slowly open the ball valve (2).
7. Adjust the air pressure on the pressure regulator (1) so that the pump runs smoothly.
8. Rinse the system until the cleaning agent that flows into the tank (5) is clean.
9. Close ball valve (2).

Flushing via spray gun

10. Reverse the relief valve (3).
11. Point the spray gun, without nozzle, into the tank (5) and open it.
12. Slowly open the ball valve (2).
13. Flush until clean cleaning agent flows from the spray gun.
14. Close ball valve (2).
15. When there is no pressure remaining in the system, close the spray gun.
16. Secure the spray gun.
17. Dispose of the contents of the tank (5) according to the local regulations.

Note:

During the flushing procedure, briefly press both valve depressors (V).

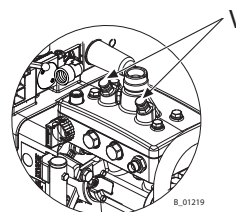
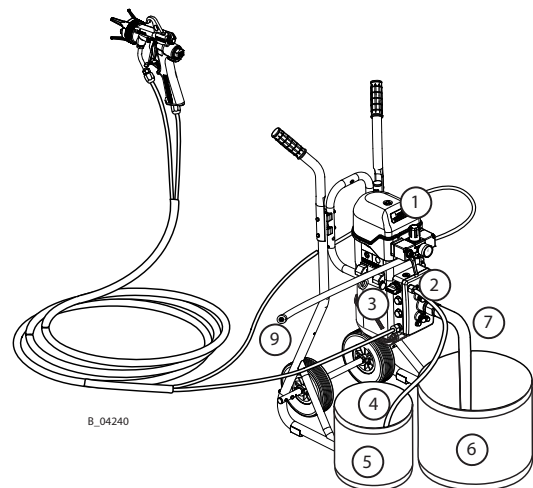

7.5.1 FILLING WITH WORKING MATERIAL

After basic flushing, the pump can be filled with working material. Proceed according to Chapter 8.2.5, but use working material instead of flushing agent.

8 CLEANING AND MAINTENANCE

8.1 CLEANING

8.1.1 CLEANING STAFF

Cleaning work should be undertaken regularly and carefully by qualified and trained staff. They should be informed of specific hazards during their training.

The following hazards may arise during cleaning work:

- Health hazard from inhaling solvent vapors.
- Use of unsuitable cleaning tools and aids.

8.1.2 DECOMMISSIONING AND CLEANING

The device should be cleaned for maintenance purposes, etc. Ensure that no remaining product dries on and sticks to the device.

Procedure

1. Carry out work interruption → Chapter [7.4](#).
2. Carry out the basic flushing → Chapter [7.5](#).
3. Empty system in a controlled manner → Chapter [8.2.4](#).
4. Service spray gun in accordance to its operating instructions.
5. Clean and check the suction system and the suction filter.
6. When using a product filter, check filter insert and filter housing and clean or replace them. → Section [8.2.6.3](#)
7. Clean the outside of the system.

WARNING

Brittle filter pressure regulator!

The tank on the filter pressure regulator becomes brittle through contact with solvents and can burst. Flying parts can cause injury.

→ Do not clean the tank on the filter pressure regulator with solvent.



8. Fully assemble the system.
9. Fill the system with flushing agent in accordance with Chapter [8.2.5](#).

8.1.3 LONG-TERM STORAGE

If storing the system for a prolonged period of time, thorough cleaning and corrosion protection are necessary. Replace the water or solvent in the product pump with a suitable preserving oil.

Procedure

1. Carry out points 1 to 8 in Chapter [8.1.2](#) "Decommissioning and Cleaning".
2. Fill the system with preservative in accordance with Chapter [8.2.5](#).
3. Empty the system in a controlled manner in accordance with Chapter [8.2.4](#) and seal the openings.

8.2 MAINTENANCE

8.2.1 MAINTENANCE STAFF

Maintenance work should be undertaken regularly and carefully by qualified and trained staff. They should be informed of specific hazards during their training.

The following hazards may arise during maintenance work:

- Health hazard from inhaling solvent vapors.
- Use of unsuitable tools and aids.

An authorized person must ensure that the device is checked for being in a reliable state after maintenance work is completed.

8.2.2 MAINTENANCE INSTRUCTIONS

DANGER

Incorrect maintenance/repair!

Danger to life and equipment damage.

- Only a WAGNER service center or a suitably trained person may carry out repairs and replace parts.
- Use only WAGNER original spare parts and accessories.
- Only repair and replace parts that are listed in the "Spare parts" chapter and that are assigned to the unit.
- Before all work on the device and in the event of work interruptions:
 - Relieve the pressure from the spray gun, high-pressure hoses and all devices.
 - Secure the spray gun against actuation.
 - Switch off the energy and compressed air supply.
 - Disconnect the control unit from the mains.
- Observe the operating and service manual for all work.



Prior to maintenance

The following state is to be ensured before carrying out any work on it:

- Flush and clean the system. → Section [8.1.2](#)
- The air supply should be interrupted.

After maintenance

- Carry out safety checks in accordance with Chapter [8.2.3](#).
- Put the system into operation and check for leaks as described in Chapter [6.7](#).
- Have the system checked for safe condition by an authorized person.
- Function test in accordance with section [11](#).

8.2.3 SAFETY CHECKS AND MAINTENANCE INTERVALS

Every day

- Check grounding: see Chapter [6.5](#)
- Check hoses, tubes and couplings: see Chapter [8.2.3.1](#)
- For each decommissioning, the process according to Chapter [8.1.2](#) must be followed.
- If the pump has to be emptied for maintenance work, proceed according to Chapter [7.5](#) and Chapter [8.2.4](#).

Weekly

- Check spraying system for damage.
- Check that the safety fixtures function properly (see Chapter [5.3](#)).

Yearly or as required

- In accordance with DGUV regulation 100-500 Chapter 2.29 and 2.36:
 - The liquid ejection devices should be checked by an expert (e.g., WAGNER service technician) for their safe working conditions as required and at least every 12 months.
 - For shut down devices, the examination can be suspended until the next start-up.

8.2.3.1 PRODUCT HOSES, TUBES AND COUPLINGS

The service life of the complete hoses between product pressure generator and application device is reduced due to environmental influences even when handled correctly.

- Check hoses, pipes, and couplings every day and replace if necessary.
- Before every commissioning, check all connections for leaks.
- Additionally, the operator must regularly check the complete hoses for wear and tear as well as for damage at intervals that he/she has set. Records of these checks must be kept.
- The complete hose is to be replaced as soon as one of the two following intervals has been exceeded:
 - 6 years from the date of the hose crimping (see fitting embossing).
 - 10 years from the date of the hose imprinting.

Fitting embossing	Meaning
xxx bar	Pressure
yymm	Crimping date (year/month)
XX	Internal code

Hose imprinting	Meaning
Wagner	Name / Manufacturer
yymm	Date of manufacture (year/month)
xxx bar (xx MPa) e.g., 270 bar (27 MPa)	Pressure
XX	Internal code
DNxx (e.g., DN10)	Nominal diameter

8.2.3.2 CONDENSATE DRAIN FROM THE AIRCOAT FILTER REGULATOR

- Frequently drain the condensate that may accumulate in the air filter.
 - Make sure the water level in the filter cup never reaches the max. level marked on the cup itself.

8.2.4 EMPTYING PUMP**⚠ WARNING****Gas mixtures can explode if there is an incompletely filled pump!**

Danger to life from flying parts.

Ignition of potentially explosive surrounding atmosphere.

- Empty the device slowly and in a controlled manner.
- Avoid potentially explosive atmosphere in the surroundings.



→ If the pumping product becomes heated, switch off all heaters and let the product cool off.

1. Visual check: personal safety equipment, grounding and all devices ready to use.
2. Place grounded collection tank (5) under the return tube (4).
3. Place the suction hose (7) in an empty, grounded tank (6).
4. Close pressure regulator (1) (0 MPa; 0 bar; 0 psi).

Empty using return line

5. Open relief valve (3).
6. Slowly open the ball valve (2).
7. Slowly turn air pressure up on the pressure regulator (1) and only until the pump is running normally (approx. 0.05 MPa; 0.5 bar; 7.25 psi).
8. Be ready for the switch from working material to air. Turn down pressure regulator (1) far enough that the pump is still running normally (approx. 0–0.05 MPa; 0–0.5 bar; 0–7.25 psi).
9. As soon as working material is no longer flowing from the return tube (4), close ball valve (2).
10. Close relief valve (3).

Empty up to the gun

11. Point the gun, without nozzle, into tank (5) and open it.
12. Slowly open the ball valve (2). Be ready for the switch from working material to air.
13. As soon as working material is no longer flowing from the return tube, close the ball valve (2).
14. Close and secure gun.
15. Depressurization in accordance with Chapter [7.4](#).
16. Dispose of the contents of the tank (5) according to the local regulations.

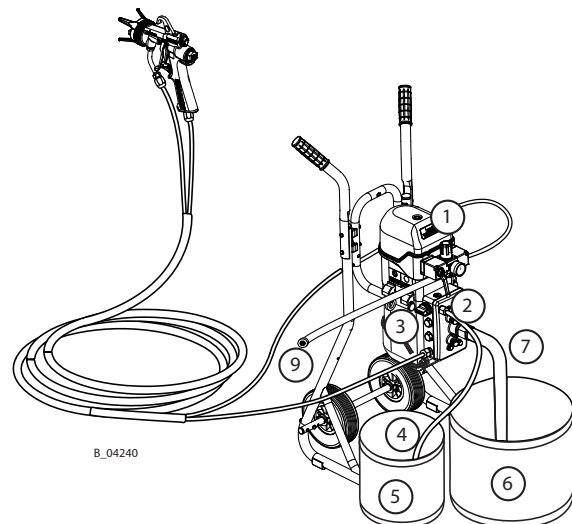

8.2.5 FILLING THE EMPTY PUMP**⚠ WARNING****Gas mixtures can explode if there is an incompletely filled pump!**

Danger to life from flying parts.

Ignition of potentially explosive surrounding atmosphere.

- Empty and fill the device slowly and in a controlled manner.
- Avoid potentially explosive atmosphere in the surroundings.



1. Visual check: personal safety equipment, grounding and all devices ready to use.
2. Place grounded collection tank (5) under the return tube (4).
3. Place the suction hose (7) in a grounded tank with working material (6).
4. Close pressure regulator (1) (0 MPa; 0 bar; 0 psi).
5. Open relief valve (3).
6. Slowly open the ball valve (2).
7. Slowly turn the air pressure up on the pressure regulator (1) and only until the pump is running normally (approx. 0–0.05 MPa; 0–0.5 bar; 0–7.25 psi).
Be ready to switch from working material to air and prevent back spray.
8. Close ball valve (2) as soon as pure working material starts coming from the return tube (4).
9. Close relief valve (3).
10. Point the spray gun, without nozzle, into the tank (5) and open it.
11. Slowly open the ball valve (2). Be ready to switch from working material to air and prevent back spray.
12. As soon as pure working material without air bubbles is flowing, close ball valve (2).
13. Close and secure the spray gun.
14. Depressurization in accordance with Chapter [7.4](#).
15. Dispose of the contents of the tank (5) according to the local regulations.

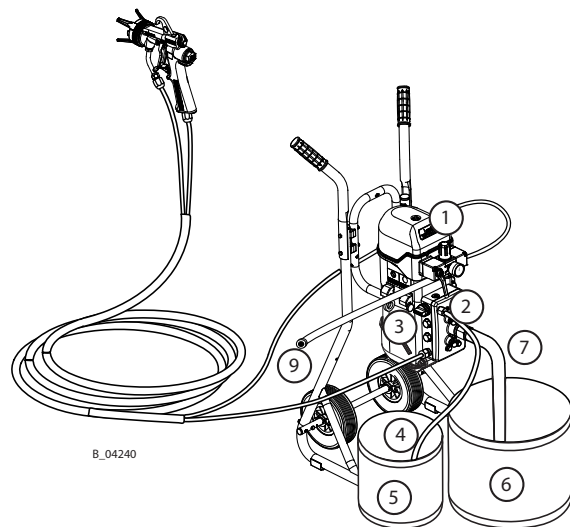

8.2.6 CLEANING AND REPLACING THE FILTER**8.2.6.1 STRAIGHT INLINE FILTER (270 BAR)**

1. Flush the pump and inline filter in accordance with Chapter [7.5](#). Flush using the gun so that the flushing agent flows through the inline filter. Maximize the flow (remove the nozzle, open the dosing valve if necessary).
2. Empty the pump in a controlled manner in accordance with Chapter [8.2.4](#).
3. Place the grounded collection tank under the inline filter.
4. If no swivel joint is mounted, remove the hose.
5. Unscrew the inlet housing (2) and outlet housing (5) with two size 19 wrenches.
6. Remove the filter insert (3).
7. If the inline filter has any leaks, replace the seal* (1).
8. Insert the new filter insert* (3). Note the installation position: Closed end in direction of flow.
9. If necessary, coat the thread with anti-seize paste**.
10. Screw together the inlet housing (2) and outlet housing (5) with two size 19 wrenches.
11. If necessary, screw the hose back on.
12. Fill the pump in accordance with Chapter [8.2.5](#).

* Order No., see Chapter [13](#).

** Order No., see Chapter [10.3](#).

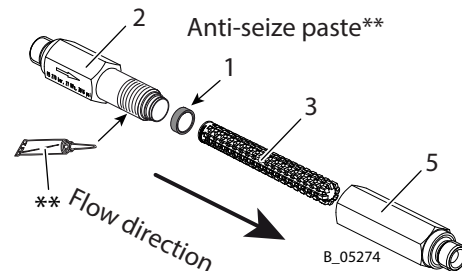

27 MPa; 270 bar; 3916 psi

8.2.6.2 ANGLED INLINE FILTER (270 BAR)

1. Flush the pump and inline filter in accordance with Chapter [7.5](#). Flush using the gun so that the flushing agent flows through the inline filter. Maximize the flow (remove the nozzle, open the dosing valve if necessary).
2. Empty the pump in a controlled manner in accordance with Chapter [8.2.4](#).
3. Place the grounded collection tank under the inline filter.
4. Unscrew the filter by turning the handle (4).
5. Remove the filter insert (3).
6. If the inline filter has any leaks, replace the seal* (1).
7. Insert the new filter insert* (3). Note the installation position: Closed end in direction of flow.
8. If necessary, coat the thread with anti-seize paste**.
9. Assemble the turning handle (4), inlet housing (2) and outlet housing (5) and tighten by turning the handle.
10. Fill the pump in accordance with Chapter [8.2.5](#).

* Order No., see Chapter [13](#).

** Order No., see Chapter [10.3](#).

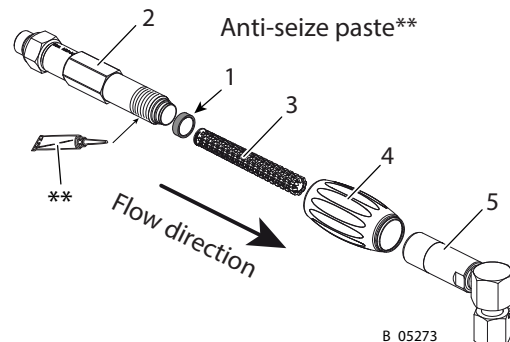

27 MPa; 270 bar; 3916 psi

8.2.6.3 HIGH-PRESSURE FILTER 530 BAR

1. Flush the pump and HP filter in accordance with Chapter [7.5](#), and while doing so:
 - At the preferred filter installation position: Flush via the return flow valve (1). This produces a large flow. As a result, the flushing agent also flows through the upper part of the filter cartridge (11). Pressure regulator approx. 0.15 MPa; 1.5 bar; 22 psi.
 - At the reversed filter installation position: Flush using the gun. This is required in the case of a reversed installation position so that the flushing agent flows through the filter cartridge (11). Maximize the flow (remove the nozzle, open the dosing valve if necessary).
2. Empty the pump in a controlled manner in accordance with Chapter [8.2.4](#).
3. Place the grounded collection tank under the High-pressure filter.
4. Open ball valve (1).
5. Loosen union nut (3) with a size 70 wrench.
6. Unscrew the union nut (3) and lift slightly so that it does not get dirty in the next step.
7. Remove the filter housing (2) with the union nut (3). The cone spring (12) remains in the filter housing (2). If the O-ring (5) is not damaged, it remains on the filter housing (2).
8. Remove the filter cartridge (11) and filter support (10) from the filter housing (2).
9. Clean all parts:
 - Place the filter cartridge (11) and filter support (10) in solvent. Clean using brush.
 - Fill the filter housing (2) approx. 1/3 full with solvent, secure wearing a glove and shake well.
 - Clean the distribution housing (7) using a brush.
10. If necessary, replace the O-ring (5) and/or filter cartridge (11). Order No., see Chapter [14.12](#).
11. Assemble all parts in reverse order. While doing so:
 - Coat the thread of the distribution housing (7) with anti-seize paste**.
 - Coat the O-ring (5) and pressure ring (21) with Mobilux® EP2**.
 - Observe the installation position of the filter cartridge (11): Push the closed end with the filter identification ahead into the filter housing (2).
 - Make sure that the cone spring (12) is in the filter housing (note the installation position). Press on the cone spring after inserting the filter cartridge (11) and filter support (10); the spring action must be noticeable.
 - Tighten the union nut (3) by hand.
12. Close ball valve (1).
13. Fill the pump in accordance with Chapter [8.2.5](#).

Filter installation position

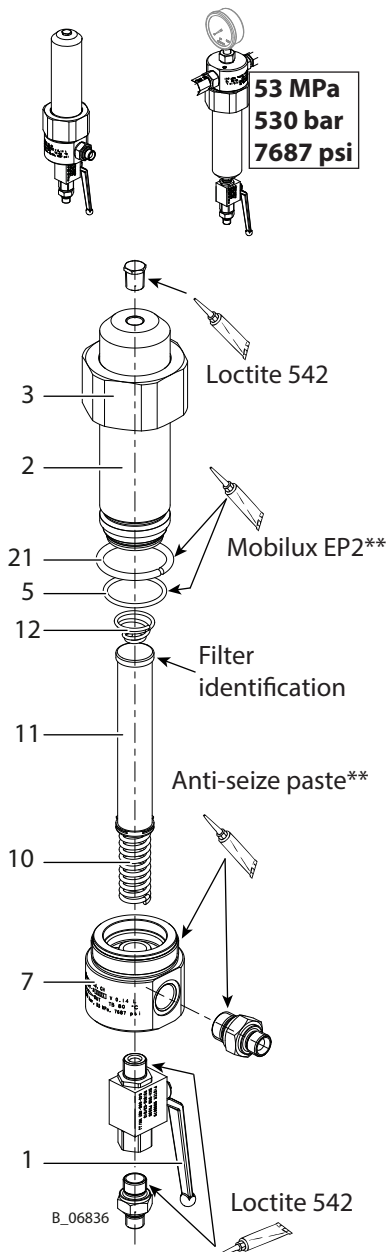

** Order No., see Chapter [13](#).

8.2.7 MAINTENANCE HYDRAULIC STAGE

Dismount the device onto a frame as shown in the picture and turn it upside down.
Observe the fill level marking (X) on the oil tank.

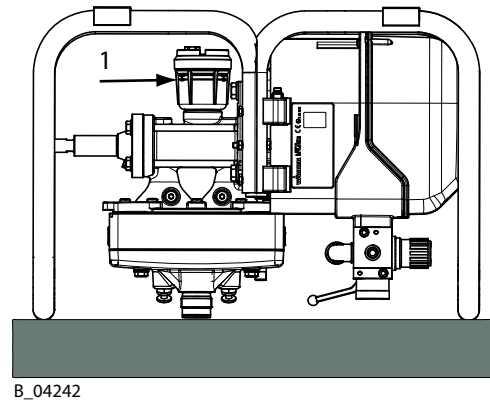
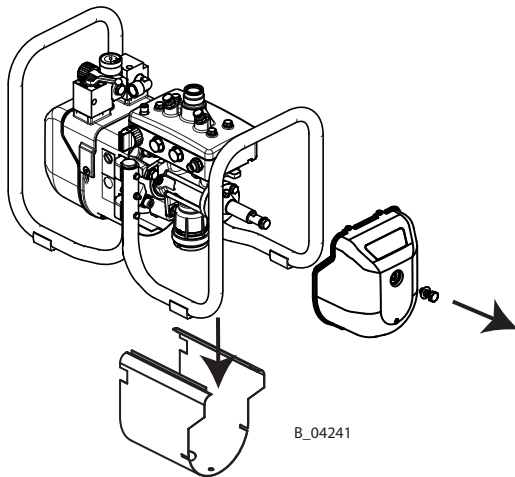

8.2.8 CHECKING THE OIL LEVEL

1. Start up the pump for a short time without any product.
2. Then read oil level A.

Dismount the device onto a frame as shown in the picture and turn it upside down.

Observe the fill level marking (X) on the oil tank.

Oil level A in the oil tank (1) has to be within the specified markings (X).

If the level deviates from these markings, the hydraulic oil must be topped up.

Procedure

1. Unscrew and remove threaded plug (5).
2. Top up oil to level A = middle of marking X.
3. Start up the pump for a short time without any product and check for air bubbles.
4. Screw in threaded plug (5) and tighten with 2 Nm; 1.5 lbft.

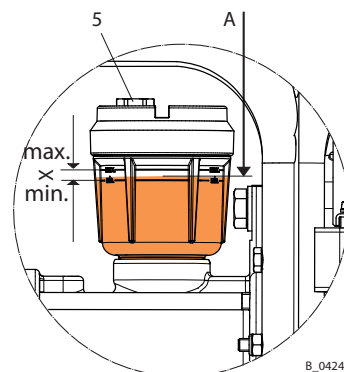

⚠ NOTICE

Using hydraulic oil

Using the wrong hydraulic oil can cause a malfunction.

→ Use only original hydraulic oil - Wagner order no. 322912 (250 ml or 15 cu inch).

8.2.9 OIL CHANGE

Perform oil change after 500 service hours or once a year.

Necessary accessories:

Order No. 322911 Oil filling set

⚠ NOTICE**Using hydraulic oil**

Using the wrong hydraulic oil can cause a malfunction.

→ Use only original hydraulic oil - Wagner order no. 322912 (250 ml or 15 cu inch).

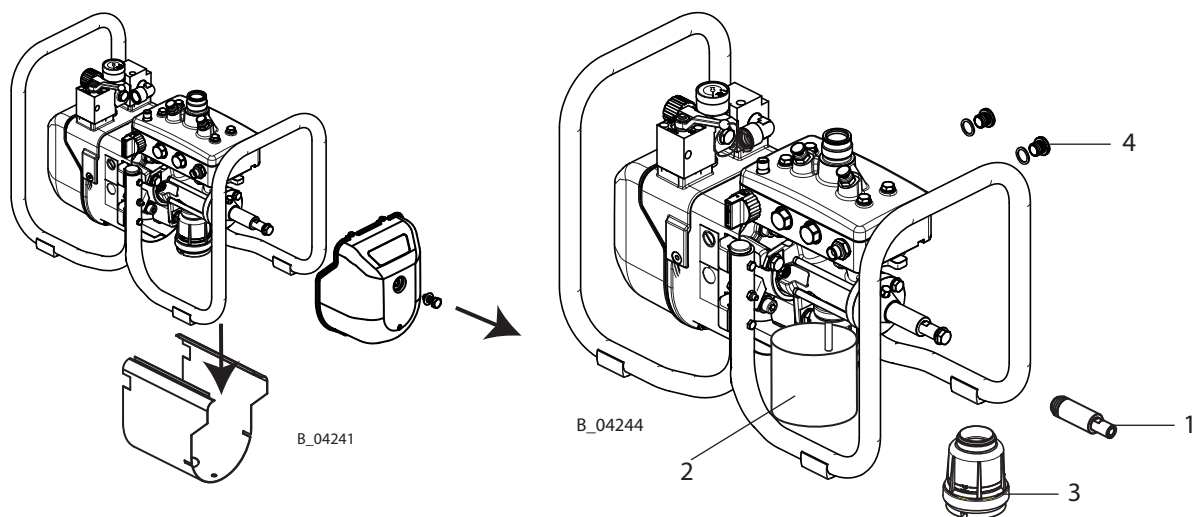
8.2.9.1 DISCHARGING OIL**Procedure**

1. Decommission and clean → Chapter [8.1.2](#) up to and including point 6.
2. Position device as shown in the picture and dismount the hood and casing.
3. Unscrew piston cover (1).
4. Place empty oil collector (2) under the oil tank.
5. Unscrew oil tank (3) and drain contents.
6. Unscrew and remove locking screws (4) and seals.
7. Slowly start up the pump until no more oil flows out of the oil intake tube.
8. Screw in clean oil tank (3) and seal.

8.2.9.2 FILLING HYDRAULIC STAGE WITH OIL**⚠ CAUTION****Environmental pollution caused by waste oil!**

Waste oil in the sewage network or spilled on the ground causes severe environmental damage.

Groundwater pollution is liable to prosecution.

→ Collect waste oil and bring it to a collection point.

→ Waste oil is taken back by the seller at the time of purchasing hydraulic oil.

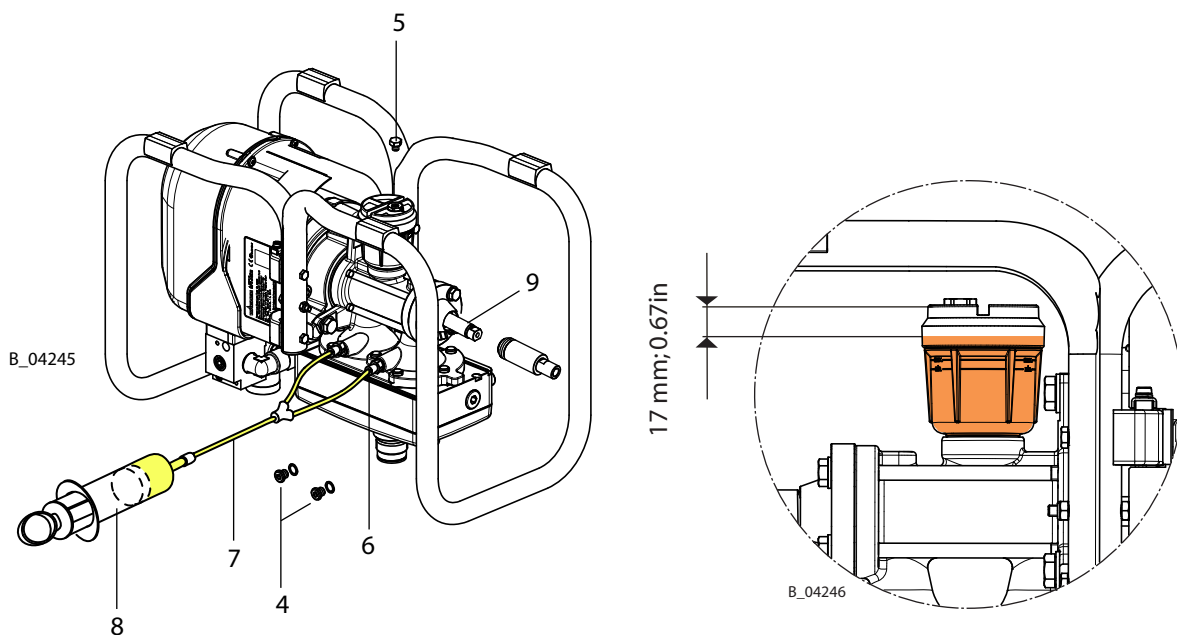
**Procedure**

1. Turn pump (mounted on the frame) upside down.
2. Unscrew and remove threaded plug (5).
3. Unscrew 2 locking screws (4) and replace with 2 screw fittings (6) from the oil filling set.
4. Connect hoses with Y-pieces (7).
5. Fill syringe (8) with hydraulic oil and insert into hose.
6. Move piston (9) into front end position. Use the syringe to fill the hydraulic stage until the oil flows out of the intake tube into the oil tank (3) with no air bubbles.
7. Move piston (9) into rear end position. Use the syringe to fill the hydraulic stage until the oil flows out of the intake tube into the oil tank (3) with no air bubbles.
8. Continue to top up the oil until the level before venting is approx. 17 mm; 0.67 inches below the upper edge of the oil tank.
9. Screw in threaded plug (5) and tighten gently. Put pump on its side and dismount oil filling set. Seal the filler openings tightly with 2 locking screws (4).

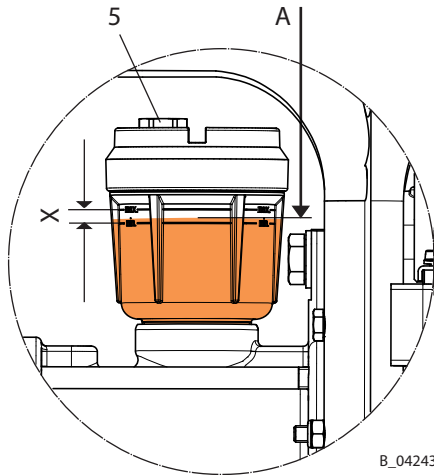
8.2.9.3 VENT

B_04243

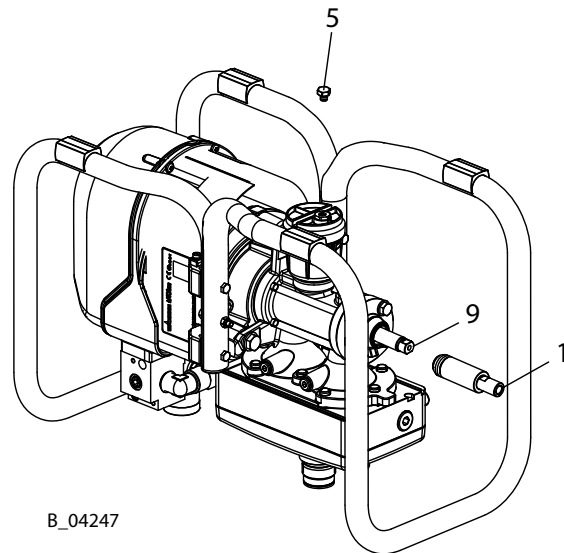

B_04247

Procedure

1. Turn the pump upside down. Remove the threaded plug (5).
2. Slowly start up the pump (vent), until no more air bubbles rise from the oil intake tube.
3. Oil level A in the oil tank has to be within the specified markings (X).
4. Screw in threaded plug (5) and tighten with 2 Nm; 1.5 lbft.
5. Mount piston cover (1) and hood with casing.
6. Return device to correct setup position.
7. The device is ready for operation again.

9 TROUBLESHOOTING AND RECTIFICATION

Problem	Cause	Remedy
The pump does not work.	Air motor does not work or stops.	Open and close ball valve on the pressure regulator unit or briefly disconnect compressed air supply.
	No pressure indication on the pressure gauge (air pressure regulator defective).	Disconnect compressed air supply briefly or repair or change pressure regulator.
	Spray nozzle is clogged.	Clean the nozzle according to the instructions.
	Insufficient compressed air supply.	Check compressed air supply.
	Filter insert in spray gun or high-pressure filter is clogged.	Clean the parts and use a suitable working material.
	The fluid section or high-pressure hose is blocked (e.g., the 2K product has hardened).	Dismount and clean fluid section, replace high-pressure hose.
	Grease in spool and sleeve assembly.	Degrease spool and sleeve assembly.
Pump stops at the stroke end occasionally.	Check detent body.	
Poor spray pattern.	See spray gun instructions.	
Irregular operation of product pump: spray jet collapses (pulsation)	Viscosity is too high.	Thin spraying product.
	Spraying pressure is too low.	Increase incoming air pressure.
		Use a smaller nozzle.
	Valves are clogged.	Press valve depressor.
		Clean product pump and leave to soak in cleaning agent if necessary.
	Foreign body in suction valve.	Dismantle suction valve housing, clean and check valve seat.
	Diameter of compressed air line too small.	Assemble a larger supply line → Technical data, see Chapter 5.5.2 .
Valves, packings, or pistons are worn out.	Replace the parts.	
Control air filter or work air filter is clogged.	Check filter and clean it if necessary.	
Strongly irregular operation of product pump.	Diaphragms "blocked" because suction is too fast.	Operate pump with ball valve opened a minimal amount for a while.
The pump runs evenly, does not however, suck up product.	The suction system's union nut is loose; the pump is taking in air.	Tighten.
	Suction filter is clogged.	Clean filter.
	Valves are clogged.	Press valve depressor.
Clean product pump and leave to soak in cleaning agent if necessary.		
Pump runs fast when the spray gun is closed.	Valves worn.	Replace the parts.
Loss of power due to severe icing.	There is a lot of condensation water in the air supply.	Install a water separator.

If none of the causes of malfunction mentioned are present, the defect can be remedied by a WAGNER Service Center.

10 REPAIR WORK

10.1 REPAIR STAFF

Repair work must be carried out carefully and by qualified and trained personnel. They should be informed of specific hazards during their training.

The following hazards may arise during repair work:

- Health hazard from inhaling solvent vapors.
- Use of unsuitable tools and aids.

A skilled person must check to ensure that the device is in a reliable state after it is repaired. Carry out function test in accordance with Chapter [11](#).

10.2 REPAIR NOTES

DANGER

Incorrect maintenance/repair!

Danger to life and equipment damage.

- Only a WAGNER service center or a suitably trained person may carry out repairs and replace parts.
- Use only WAGNER original spare parts and accessories.
- Only repair and replace parts that are listed in the "Spare parts" chapter and that are assigned to the unit.
- Before all work on the device and in the event of work interruptions:
 - Relieve the pressure from the spray gun, high-pressure hoses and all devices.
 - Secure the spray gun against actuation.
 - Switch off the energy and compressed air supply.
 - Disconnect the control unit from the mains.
- Observe the operating and service manual for all work.



Before a Repair

- Flush and clean the system. → Section [8.1.2](#)
- The air supply should be interrupted.

After a Repair

- Carry out safety checks in accordance with Chapter [8.2.3](#).
- Put the system into operation in accordance with Chapter [6.7](#) and check for leaks in accordance with Chapter [11](#).
- Function test in accordance with section [11](#).

10.3 TOOLS

The following tools are required for carrying out the repair work described below on the Cobra pump:

- Open-end wrenches, size 3; 5; 7; 8; 10; 12; 13; 14; 15; 16; 17; 18; 19; 22; 24; 27; 36; 50.
- Allen wrench, size 10.
- Screwdriver, size 3.
- Torque wrench 40 Nm; 29.5 lbft.

10.4 CLEANING THE PARTS AFTER DISASSEMBLY**⚠ WARNING****Incompatibility of cleaning agent and working medium!**

Risk of explosion and danger of poisoning by toxic gases.

- Examine the compatibility of the cleaning agents and working media on the basis of the safety data sheets.

**Please note:**

- Thoroughly clean all reusable parts with a suitable cleaning agent.
- All uninstalled parts have to be clean and dry after cleaning. Care should be taken that these parts remain free of solvents, grease or sweat from the hands (salt water). Clean and mount wearing gloves.

10.5 ASSEMBLY OF THE DEVICE

In Chapter [14](#) the order numbers for device spare parts can be found, as well as for wearing parts such as seals.

- Defective parts, O-rings and seal sets must always be re-placed.
- Use greases and glues in accordance with Chapter [14](#).
- Observe torque specifications in Chapter [14](#).

Mounting materials

Order No.	Quantity	Designation	Smaller tanks
9992590	1 pc \triangleq 50 ml	Loctite® 222	
9992511	1 pc \triangleq 50 ml	Loctite® 243	
9992528	1 pc \triangleq 150 g	Loctite® 270	
9992831	1 pc \triangleq 50 ml	Loctite® 542	
9998808	1 pc \triangleq 18 kg!	Mobilux® EP 2 grease	400 g tube \triangleq Order No. 2355418
9992616	1 pc \triangleq 1 kg can	Molykote® DX grease	50 g tube \triangleq Order No. 2355419
322912	1 pc \triangleq 250 ml	Hydraulic oil - Wagner	

Brand notice

The brands specified in this document are property of the respective owners. Loctite®, for example, is a registered brand of Henkel.

11 FUNCTION TEST AFTER THE REPAIR

After all repairs, the device must be checked for safe condition before recommissioning. The necessary scope of inspection and testing depends on the repair carried out and must be documented by the repair staff.

Activities	Aid tools
<p>1. Piston travel</p> <ul style="list-style-type: none"> – It must be possible to move the piston rod on both sides up to stop with a pre-assembled pressure stage. Balancing bore must be completely open in the respective end position (Visual inspection, see Chapter 14.4). 	Manual inspection
<p>2. Oil filling</p> <ul style="list-style-type: none"> – Mount pressure and fluid section on frame. Push piston into air motor-side end position. Fill pre-assembled pump with oil via filling port until oil is visible in the oil tank. Push piston into the opposite end position. Fill pump further with oil until just below end of oil tank inspection window (see Chapter 8.2.9). 	Oil filling unit
<p>3. EX-relevant inspections</p> <ul style="list-style-type: none"> – Check mass connection between grounding connection of the pump and the frame/trolley and between the individual components of the frame/trolley: <math><100\text{k}\Omega</math> – Check conductivity between the piston and the grounding connection: <math><100\text{k}\Omega</math> <p>These inspections are  – relevant!!</p>	Ohmmeter
<p>4. Testing for leaks</p> <ul style="list-style-type: none"> – Connect the air motor to the air supply 6 bar. To perform a leak test on the device, the product pressure with the flushing agent is slowly increased in increments until the maximum pressure indicated on the type plate is reached. Close pump outlet. Allow to stand in this position for 0.5-1 minute and listen for audible blowing off. Close air-supply ball-valve without relieving and check for pressure-loss. Check seal of following modules: <ul style="list-style-type: none"> – Flange seal – Ball valve (in all positions) – Pressure stage – Fluid section 	<p>Air motor: Test medium compressed air Leak spray</p> <p>Fluid section: Test medium: suitable flushing agent</p>
<p>5. General inspections</p> <ul style="list-style-type: none"> – Check tightening torque of various screws. Tighten hexagon screws M12x65 (40-10) or M16x80 (40-25) and input valve housing with the prescribed torque (see Chapter 14). – Check all threaded connections. – Empty the device completely and relieve pressure. – Check function of frame or transport trolley. Check whether the pump is mounted horizontally on the frame. 	Torque wrench Visual check

12 DISPOSAL

When the equipment must be scrapped, please differentiate the disposal of the waste materials.

The following materials have been used:

- Stainless steel
- Aluminum
- Elastomers
- Plastics
- Carbide

Consumable products

Consumable products (lacquers, adhesives, flushing and cleaning agents, solvents) must be disposed of in accordance with all applicable legal requirements.

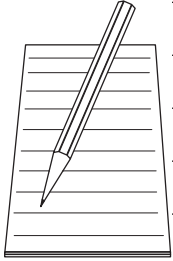

A series of horizontal lines for writing, starting from the top right of the notepad icon and extending across the page.



13 ACCESSORIES

13.1 COBRA 40-10 ACCESSORIES

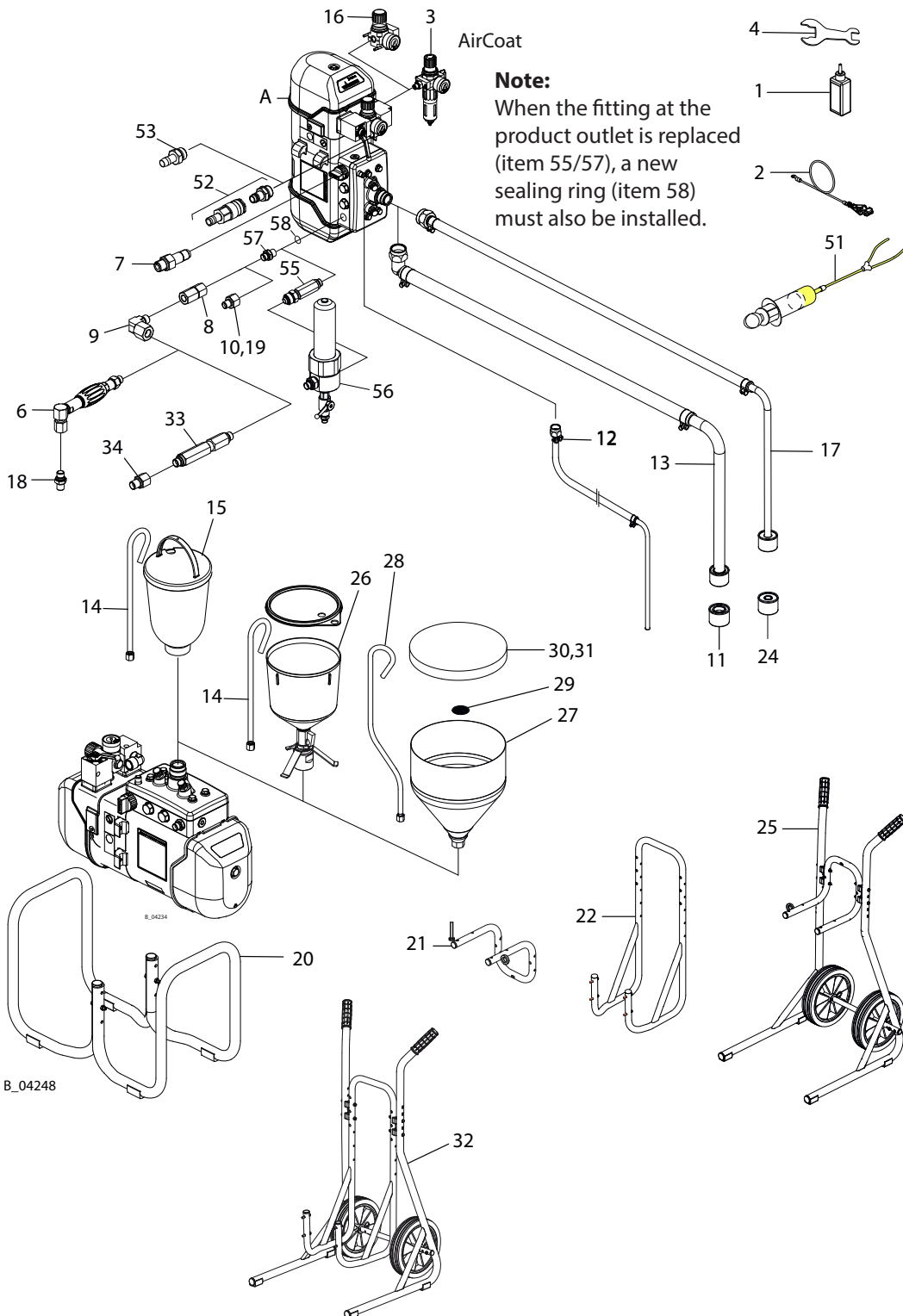

Pos	K	Order No.	Designation
A		2329519	Diaphragm pump Cobra 40-10
1	◆	322912	Hydraulic oil (for pressure stage) 250 ml; 250 cc
2	◆	236219	Grounding cable 3 m; 9.8 ft
3		2382997	AirCoat filter pressure regulator
4		341434	Double open-end wrench
6		2329026	Inline filter, HL DN6-PN270-G1/4"-SSt
7		2325343	Fitting, DF-MM-R1/4"-M12-PN270-SSt
8		2341068	Fitting, SF-FF-G3/8-G1/4-530 bar-SSt
9		2331273	Fitting, EF-FM-G1/4-G1/4-530 bar-SSt
10		2332621	Fitting RF-FM-G3/8-1/4NPSM-530 bar-SSt
11		2323325	Air suction filter DN25
12		2329046	Return hose DN6-PN310-G1/4"-PA
13		2324116	DN25 suction hose
14		2333163	Return tube for item 15
15		2344505	5-liter hopper set for Cobra
16		2328611	AirCoat regulator set
17		2324110	DN16 suction hose
18		2330774	Fitting, DF-MM-G1/4-1/4NPSM-530 bar-SSt
19		2332620	Fitting RF-FM-G3/8-3/8NPSM-530 bar-SSt
20		322052	Frame, complete
21		2332143	Wall mount 4", complete
22		2349756	Wall mounting long
24		2323396	Air suction filter DN16
25		2325901	Trolley 4", complete
26		2344741	2 L tank for Cobra
27		2341278	20 L tank for Cobra
28		2345265	Exhaust pipe 20L
29		3767	Filter disk D51
30		2304620	Drum cover 365-B
31		2304439	Drumcover 365-E
32		2341375	Cobra trolley, complete
33		2324558	Inline filter DN6-PN270-G1/4"-SSt
34		2332619	Fitting RF-FM-G1/4-1/4NPSM-530 bar-SSt
51	◆	322911	Oil filling set with 100 ml; 100 cc syringe
52	◆	322916	Air coupling set DN 10 mm; 0.39 inch
53	◆	9985619	Hose connector with sealing ring
55		2329922	Fitting SF-MM-G3/8"-M24-PN530-SSt
56		2335334	HP filter DN12-PN530-CS, complete
57		2330775	Fitting, DF-MM-G3/8-G3/8-530 bar-SSt
58		9974112	Sealing ring for G3/8 thread

◆ = Wearing parts.

Regarding item 7: Fitting (7) can be screwed in instead of the relief valve. In this case, the required ball valve must be provided by the customer. The return hose can no longer be connected to the "return socket" output.



13.2 COBRA 40-25 ACCESSORIES

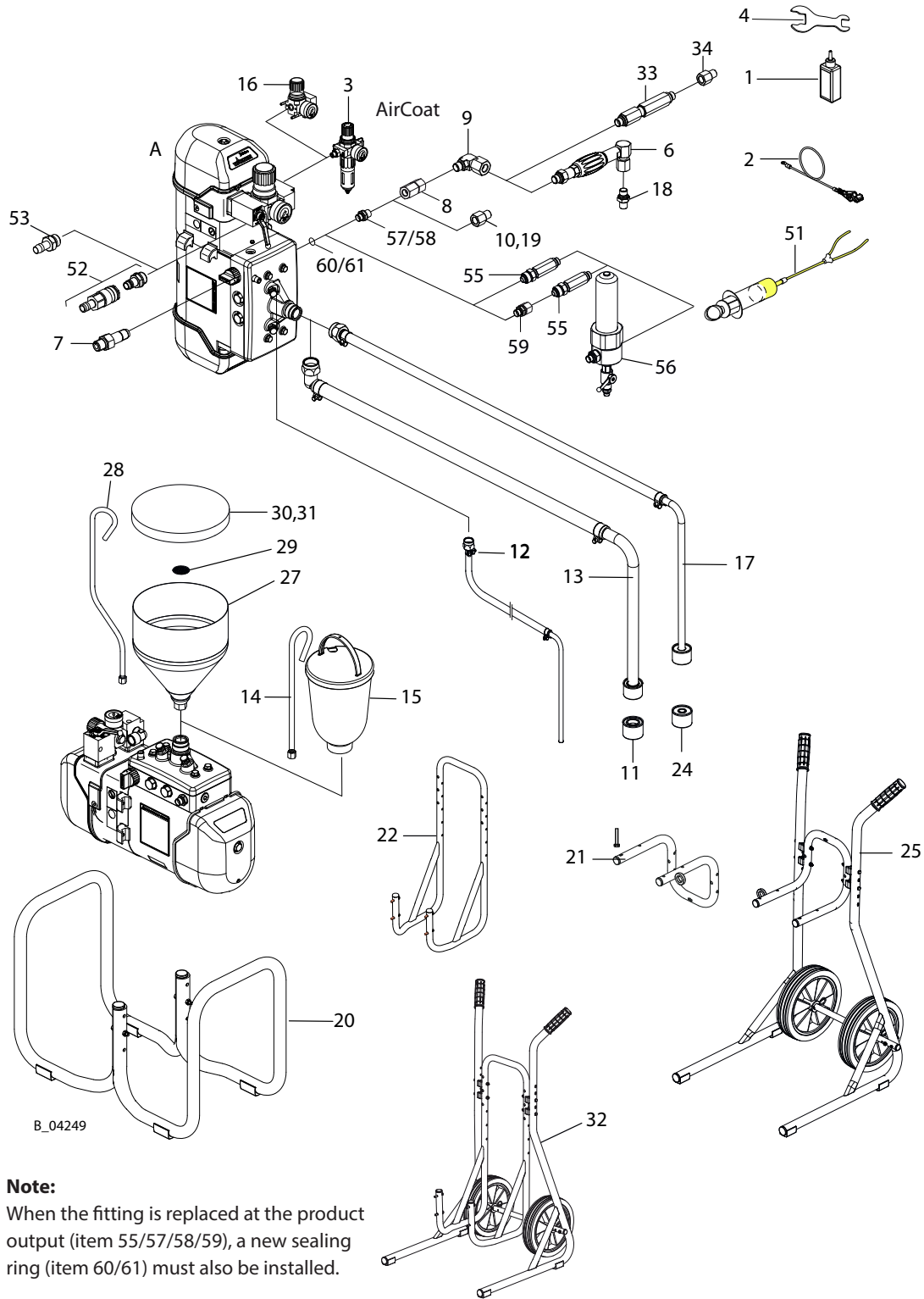

B_04249

Note:
When the fitting is replaced at the product output (item 55/57/58/59), a new sealing ring (item 60/61) must also be installed.

Pos	K	Order No.	Designation
A		2329523	Diaphragm pump Cobra 40-25
1	◆	322912	Hydraulic oil (for pressure stage) 250 ml; 250 cc
2	◆	236219	Grounding cable 3 m; 9.8 ft
3		2333479	AirCoat filter pressure regulator
4		341434	Double open-end wrench
6		2329026	Inline filter, HL DN6-PN270-G1/4"-SSt
7		2325343	Fitting, DF-MM-R1/4"-M12-PN270-SSt
8		2341068	Fitting, SF-FF-G3/8-G1/4-530 bar-SSt
9		2331273	Fitting, EF-FM-G1/4-G1/4-530 bar-SSt
10		2332621	Fitting RF-FM-G3/8-1/4NPSM-530 bar-SSt
11		2323325	Air suction filter DN25
12		2329046	Return hose DN6-PN310-G1/4"-PA
13		2324116	DN25 suction hose
14		2333163	Return tube for item 15
15		2344505	5-liter hopper set for Cobra
16		2328611	AirCoat regulator set
17		2324110	DN16 suction hose
18		2330774	Fitting, DF-MM-G1/4-1/4NPSM-530 bar-SSt
19		2332620	Fitting RF-FM-G3/8-3/8NPSM-530 bar-SSt
20		2308732	Cobra 40-25 frame
21		2332143	Wall mount 4", complete
22		2349756	Wall mounting long
24		2323396	Air suction filter DN16
25		2325901	Trolley 4", complete
27		2341278	20 liter tank
28		2345265	Exhaust pipe 20L
29		3767	Filter disk D51
30		2304620	Drum cover 365 B
31		2304439	Drumcover 365-E
32		2341375	Cobra trolley, complete
33		2324558	Inline filter DN6-PN270-G1/4"-SSt
34		2332619	Fitting RF-FM-G1/4-1/4NPSM-530 bar-SSt
51	◆	322911	Oil filling set with 100 ml; 100 cc syringe
52	◆	322916	Air coupling set DN 10 mm; 0.39 inch
53	◆	9985619	Hose connector with sealing ring
55		2329922	Fitting SF-MM-G3/8"-M24-PN530-SSt
56		2335334	HP filter DN12-PN530-CS, complete
57		2330775	Fitting, DF-MM-G3/8-G3/8-530 bar-SSt
58		2330780	Fitting, DF-MM-G1/2-G3/8-530 bar-SSt
59		2333058	Fitting, SF-FM-G3/8-G1/2-530 bar-SSt
60	◆	9974112	Sealing ring for G3/8 thread
61	◆	3051041	Sealing ring for G1/2 thread

◆ = Wearing parts.

Note: When using the HP filter (item 56), the respective appropriate fitting must be used (for product outlet fluid sections 1/2", the two fittings pos. 55 and 59 are required; for product outlet fluid sections 3/8", only fitting item 55 is required). The suitable sealing ring (item 60/61) must also be used.

Regarding item 7: Fitting (7) can be screwed in instead of the relief valve. In this case, the required ball valve must be provided by the customer. The return hose can no longer be connected to the "return socket" output.

14 SPARE PARTS

14.1 HOW CAN SPARE PARTS BE ORDERED?

Always supply the following information to ensure delivery of the right spare part:

Order number, designation and quantity

The quantity need not be the same as the number given in the quantity column "**Stk**" on the list. This number merely indicates how many of the respective parts are used in each component.

The following information is also required to ensure smooth processing of your order:

- Address for the invoice
- Address for delivery
- Name of the person to be contacted in the event of any queries
- Type of delivery (normal mail, express delivery, air freight, courier etc.)

Identification in spare parts lists

Explanation of column "**K**" (labeling) in the following spare parts lists:

- ◆ Wearing parts Wearing parts are not included in the warranty terms.
- ★ Included in service set

Notice

Note: These parts are not covered by warranty terms

- Not part of standard equipment, available, however, as additional extra.

Explanation of Order No. column

- Item not available as spare part.
- / Position does not exist.

DANGER

Incorrect maintenance/repair!

Danger to life and equipment damage.

- Only a WAGNER service center or a suitably trained person may carry out repairs and replace parts.
- Use only WAGNER original spare parts and accessories.
- Only repair and replace parts that are listed in the "Spare parts" chapter and that are assigned to the unit.
- Before all work on the device and in the event of work interruptions:
 - Relieve the pressure from the spray gun, high-pressure hoses and all devices.
 - Secure the spray gun against actuation.
 - Switch off the energy and compressed air supply.
 - Disconnect the control unit from the mains.
- Observe the operating and service manual for all work.



14.2 OVERVIEW OF THE COBRA 40-10 COMPONENTS

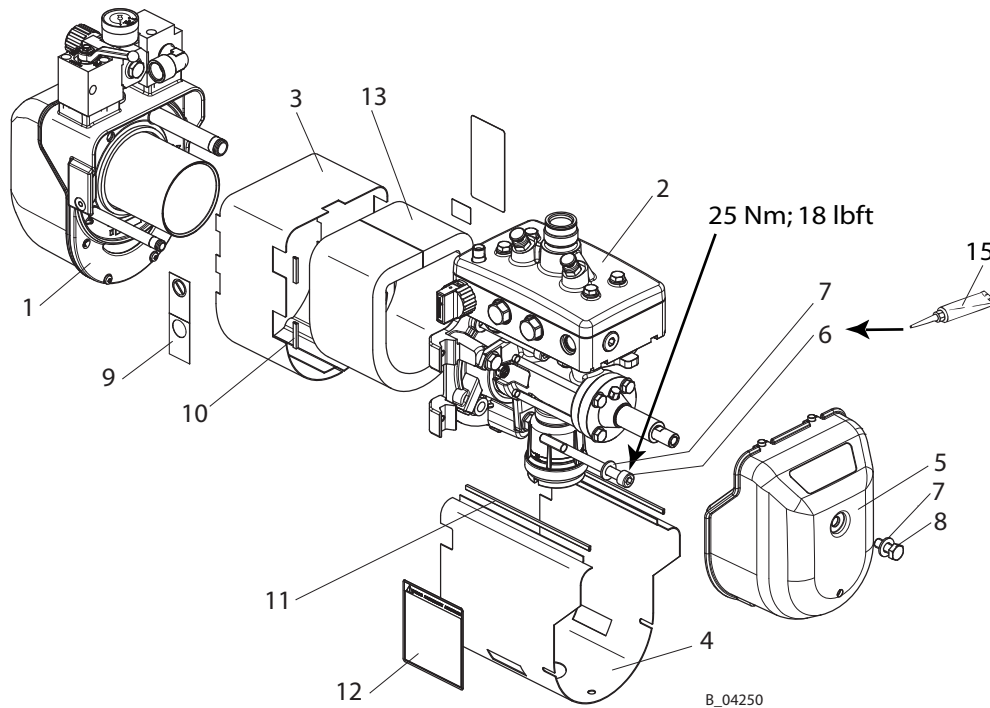

B_04250

Pos	K	Stk	Order No.	Designation
1		1	--	Air motor 3/53
2		1	--	Preassembled Cobra 40-10 fluid section
3		1	322436	Air motor casing
4		1	322437	Pressure stage casing
5		1	322235	Hood 4 with air outlet
6		3	9907224	Hexagon socket cylinder head screw
7		4	9920106	Washer
8		1	9900107	Hexagon screw
9		1	2332077	Warning label
10		4	9999211	Edge protection profile 30 mm; 1.18 inch
11		2	9999211	Edge protection profile 164 mm; 6.46 inch
12		1	2332082	Fluid warning label
13		1	322438	Cylinder noise insulation
14	◆	1	9974112	Sealing ring
15		1	9992616	Molykote DX grease

◆ = Wearing part.

OPERATING MANUAL



14.3 COBRA 40-10 AIR MOTOR

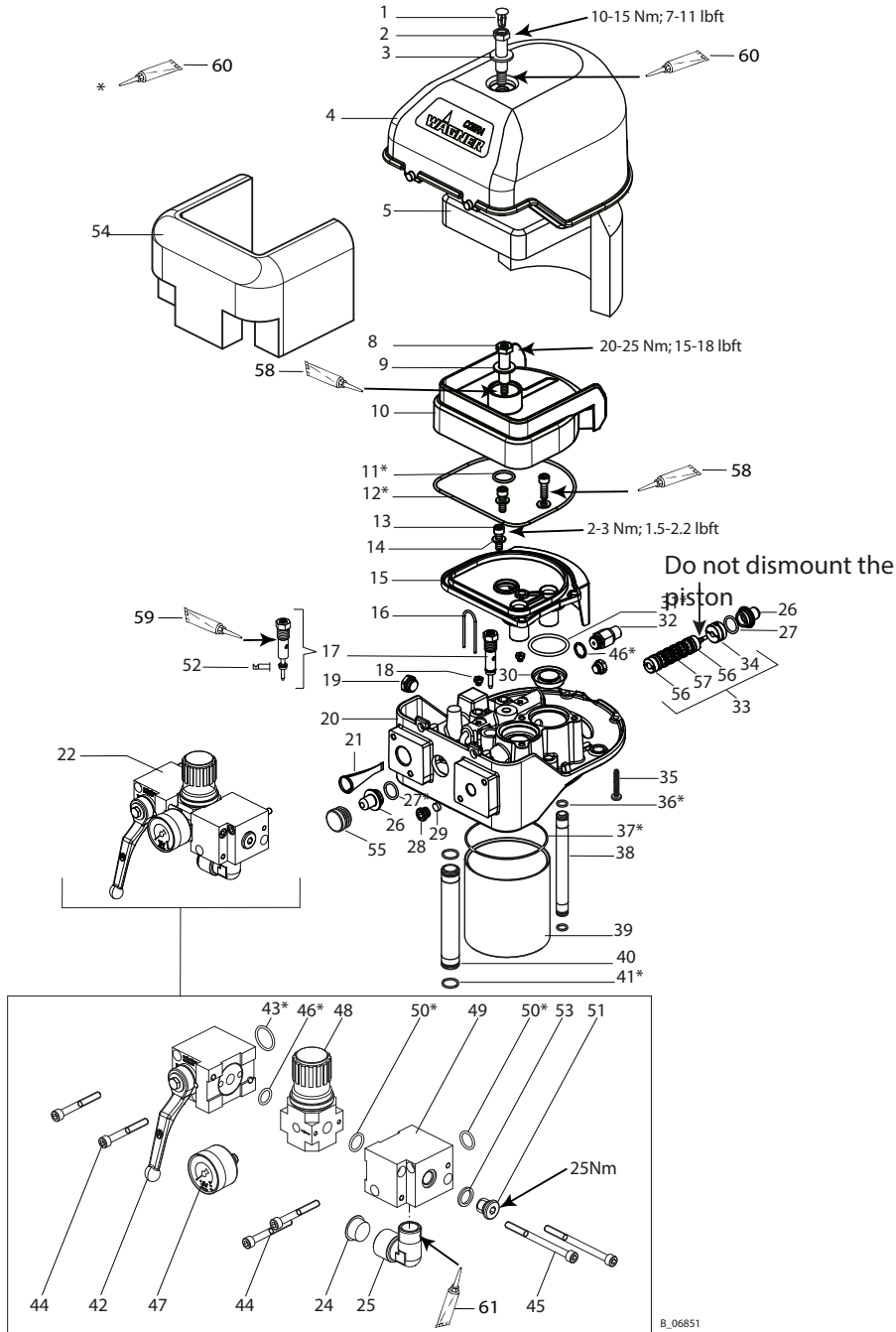

B_06851

Pos	K	Stk	Order No.	Designation
1		1	9998718	Drive fastener
2		1	367318	Shoulder screw 4
3		1	9925033	Washer
4		1	367311	Hood 4
5	◆	1	367319	Sound absorbing mat 4
8		1	367318	Shoulder screw 4
9		1	9925033	Washer

Pos	K	Stk	Order No.	Designation
10		1	367310	Silencer 4
11	◆ ★	1	9974098	O-ring
12	◆ ★	1	9974097	O-ring
13		3	9900325	Socket cap screw
14		3	9920103	Washer A6.4
15		1	367309	Connecting part 4
16		2	367320	Cotter pin
17	◆	1	369290	Pilot valve
18		2	9998674	Threaded plug
19		1	9998274	Threaded plug
20		1	2359165	Control housing 4
21	◆ ★	1	367313	Compressed air filter 4/6
22		1	2328606	Pressure regulator unit 4
24		1	9990506	Cone plug, GPN 600
25		1	9999228	Screw connector L
26		2	367307	Sealing plug, 4/6
27	◆ ★	2	9974085	O-ring
28		1	367324	Filter holder
29	◆ ★	1	367314	Control air filter
30	◆ ★	1	322910	Cobra outlet seal set (consisting of 2 seals)
31	◆ ★	2	9974095	O-ring
32		1	368285	Safety valve 0.63 MPa; 6.3 bar; 91 psi
33	◆	1	9943080	Spool and sleeve assembly, complete
34	◆	1	368038	Detent body, complete, ISO 1/2
35		2	9907126	Screw SFS Plastite 45
36	◆ ★	2	9974089	O-ring
37	◆ ★	2	9974115	O-ring
38		1	322432	Control air pipe
39		1	322430	Cylinder pipe
40		1	322431	Compressed air pipe
41	◆ ★	2	9971448	O-ring
42	◆	1	2360756	Edge ball valve 4, cpl.
43	◆ ★	1	9971137	O-ring
44		4	9900316	Hexagon socket head cap screw M6x50
45		2	9907039	Hexagon socket head cap screw M6x80
46	◆ ★	1	9971313	O-ring
47	◆	1	2341175	Manometer with air regulator 0-10 bar, G1/8"
48	◆	1	2309972	Pressure regulator
49		1	2309744	Distributor LR-D-I Mini 4
50	◆ ★	2	9974166	O-ring
51		1	9904307	Locking screw with collar / hexagon socket
52	◆	1	9974217	Rod seal
53		1	9970154	Sealing ring
54	◆	1	322439	Air motor noise insulation
55		1	9990861	Ribbed plug
56	◆	2	368313	Damper ISO1 and ISO2
57	◆	6	9971123	O-ring
58		1	9992590	Loctite 222 50 ml; 50 cc
59		1	9992831	Loctite 542 50 ml; 50 cc
60		1	9992616	Molykote DX grease
61		1	9992528	Loctite 270 50 ml; 50 cc
			2341627	Cobra 40-10 air motor service set

◆ = Wearing part.

★ = Included in service set.

OPERATING MANUAL



14.4 COBRA 40-10 FLUID SECTION

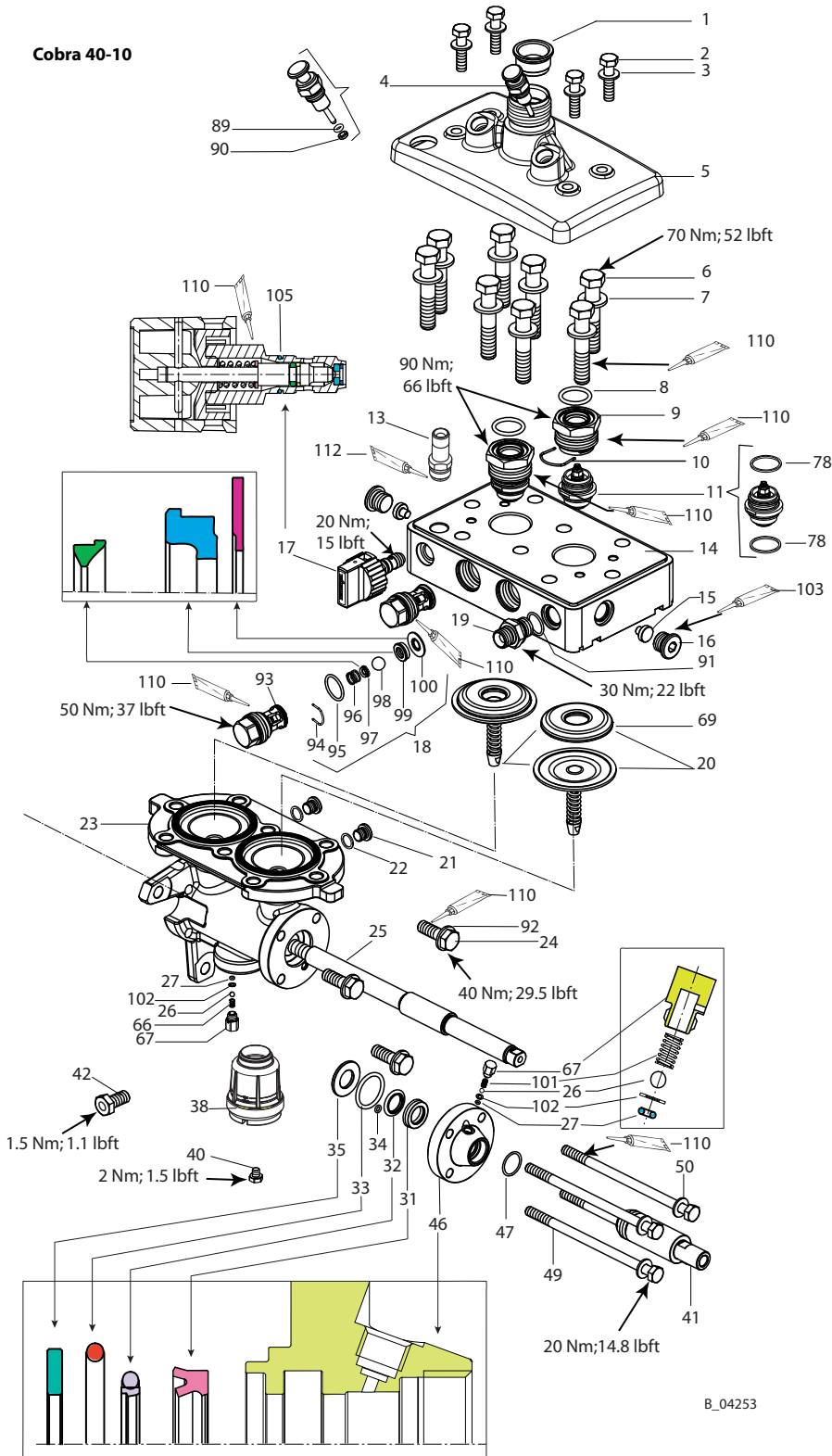

Pos	K	Stk	Order No.	Designation
1		1	2329898	Sealing sleeve
2		4	9900204	Hexagon screw
3		4	9920102	Washer
4		2	341241	Inlet valve depressor, complete, see Chapter 14.10
5		1	2330764	Inlet housing
6		8	9907234	Hexagon screw
7		10	9920107	Washer
8	◆ ★	2	9974184	O-ring
9		2	322411	Valve fitting
10		2	341336	Clasp
11	◆ ★	1	322914	Inlet valve set, complete (comprising 2 valves), see Chapter 14.9
13		1	2330810	Connection piece
14		1	322410	Fluid section
15		2	322412	Plug
16		2	9904311	Screw plug
17	◆	1	169248	Relief valve, complete, see Chapter 14.11
18	◆ ★	1	322915	Outlet valve set, complete (spare parts for 2 valves)
19		1	2330775	Fitting, DF-MM-G3/8-G3/8-530 bar-SSt
20	◆ ★	1	322913	Complete diaphragm set with insert (comprising 2 diaphragms)
21		2	9904306	Screw plug
22	◆	2	9970127	Sealing ring
23		1	2338520	Pressure stage D19/53
24		3	9907041	Hexagon screw
25		1	322402	Piston rod D19/53
26		2	9941502	Ball
27	◆	2	9971189	O-ring
29		1	9962028	Permaglide bushing
30		1	322403	Pressure stage flange
31	◆	2	9974182	Rod sealing profile BS
32	◆	2	9974183	Rod sealing set
33	◆	2	9974186	O-ring
34	◆	2	9971446	O-ring
35		2	322405	Pressure disk
37	◆	1	115944	O-ring
38		1	2352719	Oil tank set
40		1	9998274	Threaded plug G1/4
41		1	322435	Piston cover
42		1	2334842	Pressure relief valve
46		1	322404	Pressure stage cover disk
47	◆	1	9974074	O-ring
49		4	9907233	Hexagon screw
50		4	9920102	Washer
51		1	2386160	Self-locking hexagon nut (new)
		1	9910101	Hexagon nut, secured with Loctite® 243 (old version!)
53	◆	2	322427	Damping washer
54	◆	1	9974181	Piston sealing profile Z5
55		1	322426	Piston air motor 3
57	◆	1	9974115	O-ring
59	◆	2	9974185	Seal wiper ring, profile EM
60		1	2344068	Air motor flange
61		1	367258	Grounding, complete
62	◆	1	369290	Pilot valve
63		1	9998675	Threaded plug
66		1	9998780	Pressure spring
67		2	322407	Oil valve screw
68	◆	3	9971162	O-ring

Pos	K	Stk	Order No.	Designation
69		2	322415	Insert
70	◆	1	9974217	Rod seal
78	◆	4	341331	Sealing ring
89	◆ ★	2	9971486	O-ring (solvent-resistant)
90	◆	2	341316	Scraper
91	◆	1	9974112	Sealing ring for G3/8 thread
92		3	9920106	Washer
93		2	341325	Valve guide
94		2	341328	Clasp
95	◆	2	9971470	O-ring
96		2	341326	Pressure spring
97		2	253405	Spring support ring
98	◆	2	9941501	Ball 11 HM
99	◆	2	341327	Outlet valve seat
100	◆	2	341347	Sealing ring
101		1	9994237	Pressure spring
102	◆	2	322408	Oil valve pressure ring
103		1	9992590	Loctite 222 50 ml; 50 cc
104		1	9992831	Loctite 542 50 ml; 50 cc
105	◆ ★	1	9971395	O-ring, 10x1.25
106		1	2312288	Service set for Cobra 40-10 fluid section
107		1	322917	Service set for Cobra 40-10 piston (incl. items 25, 31, 32, 33, 59, and 108)
108		1	322930	Piston rod assembly pin
110		1	9992616	Molykote DX grease
111		1	9998808	Mobilux EP2 grease
112		1	9992528	Loctite 270 50 ml; 50 cc

◆ = Wearing part.

★ = Included in service set.

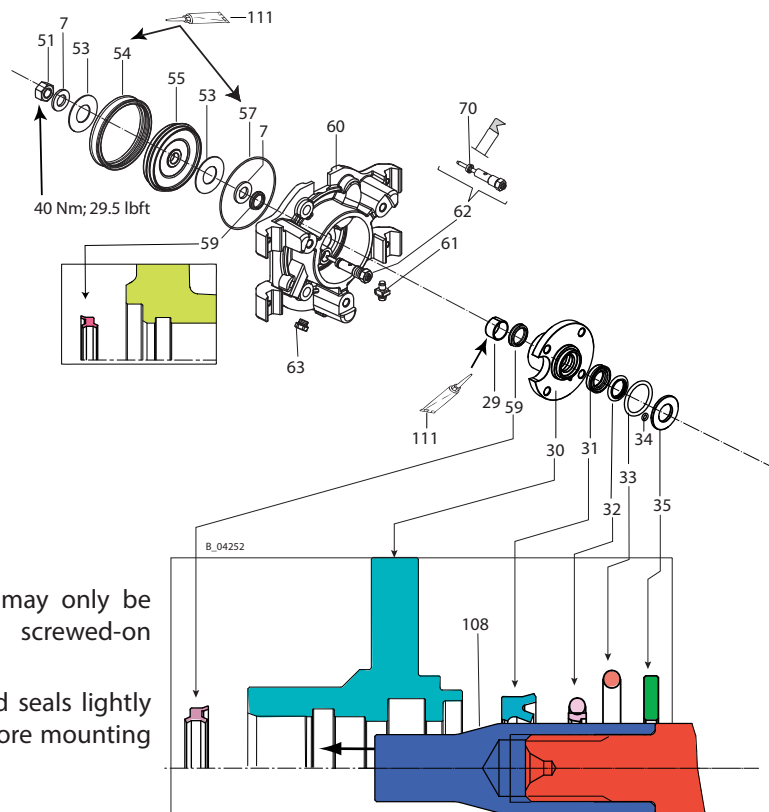

Notes:

The piston rod (25) may only be mounted with the screwed-on assembly pin (108).

Grease all o-rings and seals lightly with grease (111) before mounting them.

OPERATING MANUAL



14.5 OVERVIEW OF THE COBRA 40-25 COMPONENTS

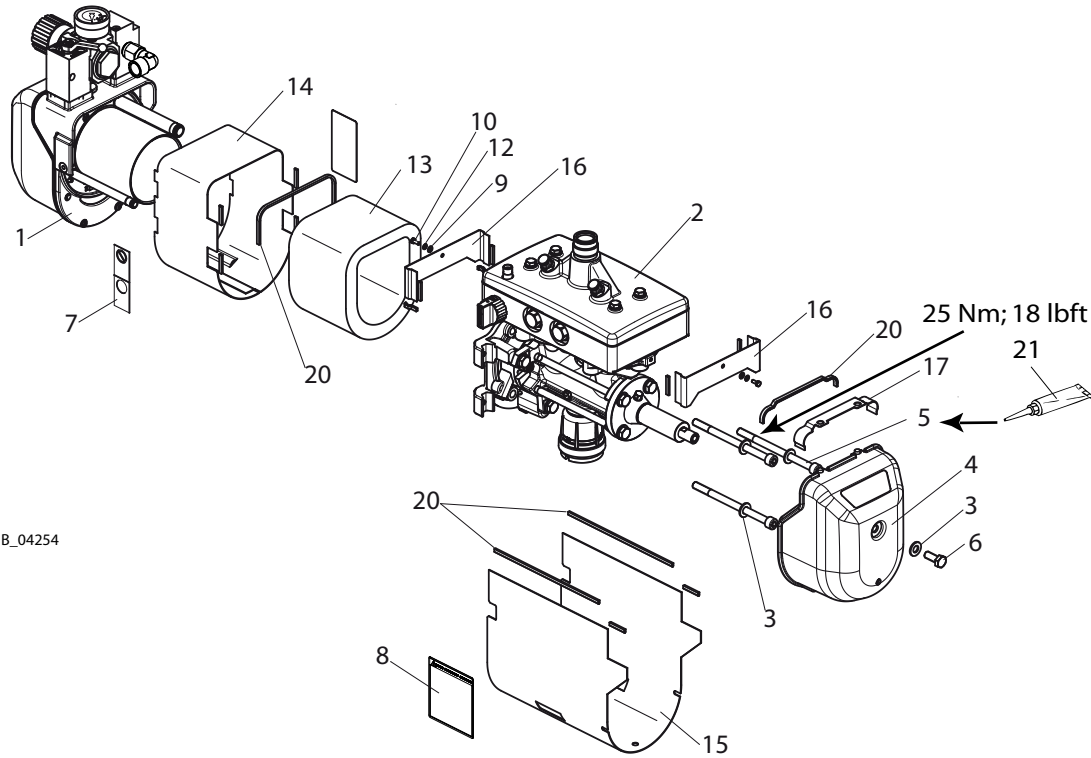

B_04254

Pos	Stk	Order No.	Designation
1	1	--	Cobra 40-25 air motor
2	1	--	Preassembled Cobra 40-25 fluid section
3	4	9920106	Washer
4	1	322235	Hood 4 with air outlet
5	3	2308693	Hexagon socket cylinder head screw
6	1	9900107	Hexagon screw without shaft
7	1	2332077	Warning label
8	1	2332082	Fluid warning label
9	2	9920104	Washer
10	2	9900152	Hexagon screw
12	2	9922107	Lock washer internal teeth
13	1	2308646	Cylinder noise insulation
14	1	2306110	Air motor casing
15	1	2306111	Pressure stage casing
16	2	2306114	Fluid section bulkhead
17	1	2308620	Pressure stage casing
20	1	9999211	Edge protection profile (total length: 0.80 m; 2.62 ft)
21	1	9992616	Molykote DX grease

OPERATING MANUAL



14.6 COBRA 40-25 AIR MOTOR

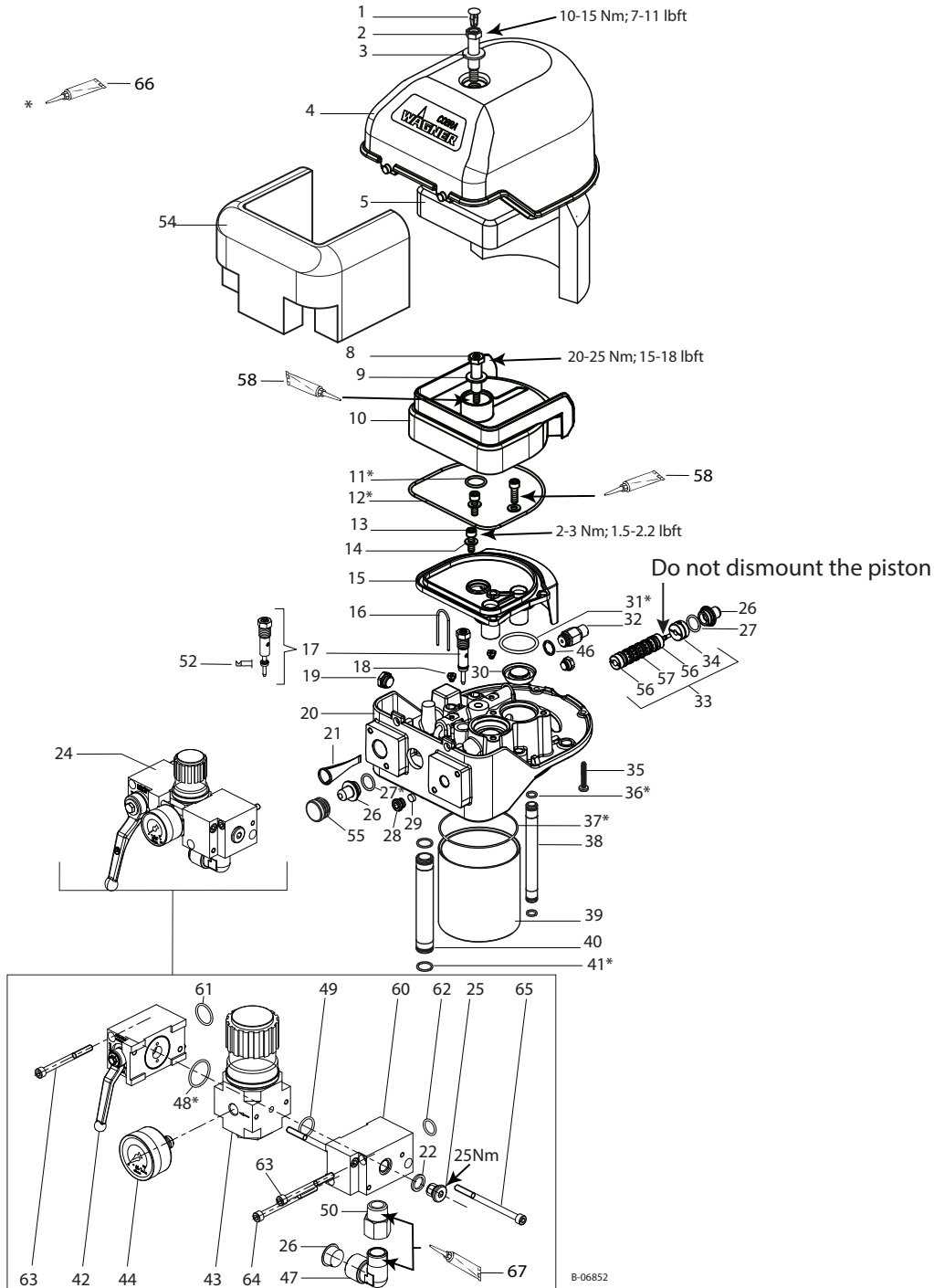

Pos	K	Stk	Order No.	Designation
1		1	9998718	Drive fastener
2		1	367318	Shoulder screw 4
3		1	9925033	Washer
4		1	367311	Hood 4
5	◆	1	367319	Sound absorbing mat 4
8		1	367318	Shoulder screw 4

Pos	K	Stk	Order No.	Designation
9		1	9925033	Washer
10		1	367310	Silencer 4
11	◆ ★	1	9974098	O-ring
12	◆ ★	1	9974097	O-ring
13		3	9900325	Socket cap screw
14		3	9920103	Washer A6.4
15		1	367309	Connecting part 4
16		2	367320	Cotter pin
17		1	369290	Pilot valve
18		2	9998674	Threaded plug
19		1	9998274	Threaded plug
20		1	2359165	Control housing 4
21	◆ ★	1	367313	Compressed air filter 4/6
22		1	9970154	Sealing ring
24		1	2328606	Cobra pressure regulator unit
25		1	9904307	Locking screw with collar / hexagon socket
26		2	9990506	Cone plug, GPN 600
27	◆ ★	2	9974085	O-ring
28		1	367324	Filter holder
29	◆ ★	1	367314	Control air filter
30	◆ ★	1	322910	Cobra outlet seal set (consisting of 2 seals)
31	◆ ★	2	9974095	O-ring
32		1	368285	Safety valve 0.63 MPa; 6.3 bar; 91 psi
33	◆	1	9943080	Spool and sleeve assembly, complete
34	◆	1	368038	Detent body, complete, ISO 1/2
35		2	9907126	Screw SFS Plastite 45
36	◆ ★	2	9974089	O-ring
37	◆ ★	2	9974084	O-ring
38		1	367305	Control air pipe
39		1	2306127	Cylinder pipe
40		1	367304	Compressed air pipe
41	◆ ★	2	9971448	O-ring
42	◆	1	2391704	Edge ball valve midi to size 4
43	◆	1	2309973	Pressure regulator valve LR-1/2-D-O-Midi
44	◆	1	2341176	Pressure gauge with air regulator 0-10 bar, G1/4"
47		1	9999228	Elbow screw-in connection R1/2 - G1/2
48	◆ ★	1	3105540	O-ring
49	◆ ★	1	9971018	O-ring
50		1	M396.00	Reducing fitting
52	◆	1	9974217	Rod seal
54	◆	1	322439	Air motor noise insulation
55		1	9990861	Ribbed plug
56	◆	2	368313	Damper ISO1 and ISO2
57	◆	6	9971123	O-ring
58		1	9992590	Loctite 222 50 ml; 50 cc
60		1	2311012	Distribution piece midi to size 4
61	◆ ★	1	9971137	O-ring
62	◆ ★	1	9974166	O-ring
63		3	9906020	Hexagon socket head cap screw M6x70
64		1	9907039	Hexagon socket head cap screw M6x80
65		2	9907014	Hexagon socket head cap screw M6x90
66		1	9992616	Molykote DX grease
67		1	9992528	Loctite 270 50 ml; 50 cc
			2341628	Cobra 40-25 air motor service set

◆ = Wearing part.

★ = Included in service set.

OPERATING MANUAL



14.7 COBRA 40-25

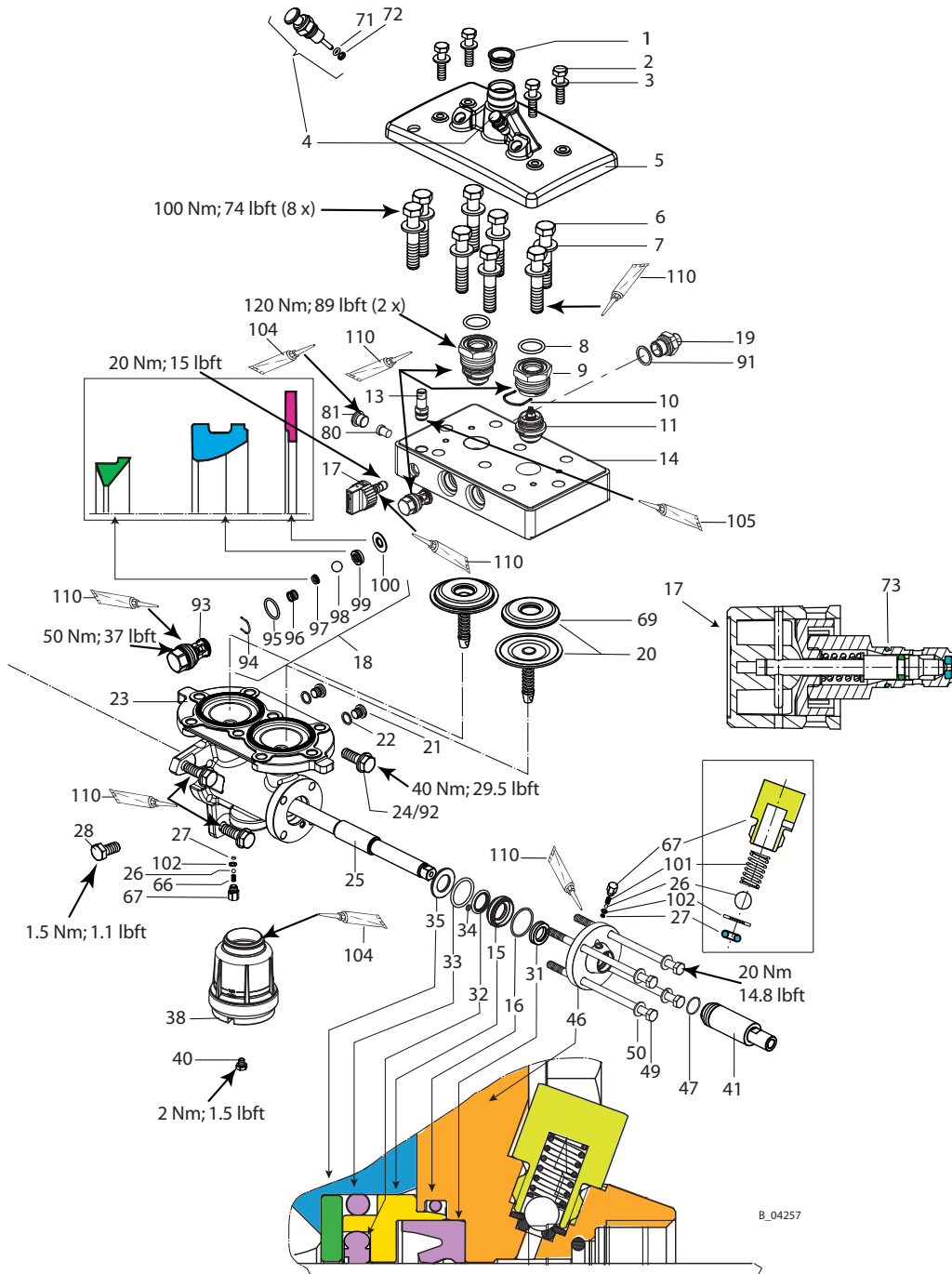

1	1	2329898	Sealing sleeve
2	4	9900204	Hexagon screw
3	4	9920102	Washer
4	2	341241	Inlet valve depressor, complete, see Chapter 14.9
5	1	2330795	Inlet housing
6	8	2306195	Hexagon screw
7	8	9925011	Washer
8	◆ ★	2306183	O-ring

Pos	K	Stk	Order No.	Designation
9		2	2306164	Valve fitting
10		2	341336	Clasp
11	◆ ★	1	2308753	Inlet valve set, complete (comprising 2 valves), see Chapter 14.8
13		1	2330810	Connection piece
14		1	2337668	Fluid section
15		2	2308868	Flange connection
16		2	2308886	O-ring
17	◆	1	169248	Relief valve, complete (for spare parts, see Chapter 14.11)
18	◆ ★	1	2308760	Outlet valve set, complete (spare parts for 2 valves)
19*		1	2330775	Fitting, DF-MM-G3/8-G3/8-530 bar-SSt
19*		1	2330780	Fitting, DF-MM-G1/2-G3/8-530 bar-SSt
20	◆ ★	1	2308754	Complete Cobra 40-25 diaphragm kit with insert (comprising 2 diaphragms)
21		2	9904306	Screw plug
22	◆	2	9970127	Sealing ring
23		1	2337746	Pressure stage
24		3	9907041	Hexagon screw
25		1	2306251	Piston rod D25/70
26		2	9941502	Ball
27	◆	2	9971189	O-ring
28		1	2334842	Pressure relief valve
29		1	2306146	Permaglide bushing
30		1	2308870	Pressure stage flange
31	◆	2	2306143	Rod sealing profile BS
32	◆	2	2306144	Rod sealing set
33	◆	2	2306145	O-ring
34	◆	2	9971446	O-ring
35		2	2306139	Pressure disk
37	◆	1	115944	O-ring
38		1	2352719	Oil tank set
40		1	9998274	Threaded plug G1/4
41		1	2306196	Piston cover
46		1	2308869	Pressure stage cover disk
47	◆	1	2306142	O-ring
49		4	9907124	Hexagon screw
50		4	9920106	Washer
51		1	2386160	Self-locking hexagon nut (new)
		1	9910101	Hexagon nut, secured with Loctite® 243 (old version!)
53	◆	2	322427	Damping washer
54	◆	1	2306204	Piston sealing profile Z5
55		1	2306205	Piston air motor 4
57	◆	1	9974084	O-ring
58		2	9920107	Washer
59	◆	1	9974090	Seal wiper ring, profile EM
60		1	2344073	Air motor flange
61		1	367258	Grounding, complete
62	◆	1	369290	Pilot valve
63		2	9998675	Threaded plug
66		1	9998780	Pressure spring
67		2	322407	Oil valve screw
68	◆	1	9971162	O-ring
69		2	2306179	Insert
70	◆	1	9974217	Rod seal
71	◆ ★	2	9971486	O-ring (solvent-resistant)
72	◆	2	341316	Scraper
73	◆ ★	1	9971395	O-ring, 10x1.25
80		1	2339251	Plug

Pos	K	Stk	Order No.	Designation
81		1	9904311	Locking screws with collar/hexagon socket
91*	◆	1	9974111	Sealing ring for G3/8 thread
91*	◆	1	3051041	Sealing ring for G1/2 thread
92		3	9920106	Washer
93		2	341325	Valve guide
94		2	341328	Clasp
95	◆	2	9971470	O-ring
96		2	341326	Pressure spring
97		2	253405	Spring support ring
98	◆	2	9941501	Ball 11 HM
99	◆	2	2306166	Outlet valve seat
100	◆	2	2306167	Sealing ring
101		1	9994237	Pressure spring
102	◆	2	322408	Oil valve pressure ring
104		1	9992831	Loctite 542 50 ml; 50 cc
105		1	9992528	Loctite 270 50 ml; 50 cc
107		1	2312289	Service set for Cobra 40-25 fluid section
108		1	2314671	Service set for Cobra 40-25 piston (incl. items 16, 25, 31, 32, 33, 59, and 109)
109		1	2314670	Piston rod assembly pin
110		1	9992616	Molykote DX grease
111		1	9998808	Mobilux EP2 grease

◆ = Wearing part.

★ = Included in service set.

* The internal thread at the product output of the fluid section (item 14) will be converted as of 2014 from G1/2" to G3/8", please use the corresponding fitting and sealing ring (see chapter "Accessories").

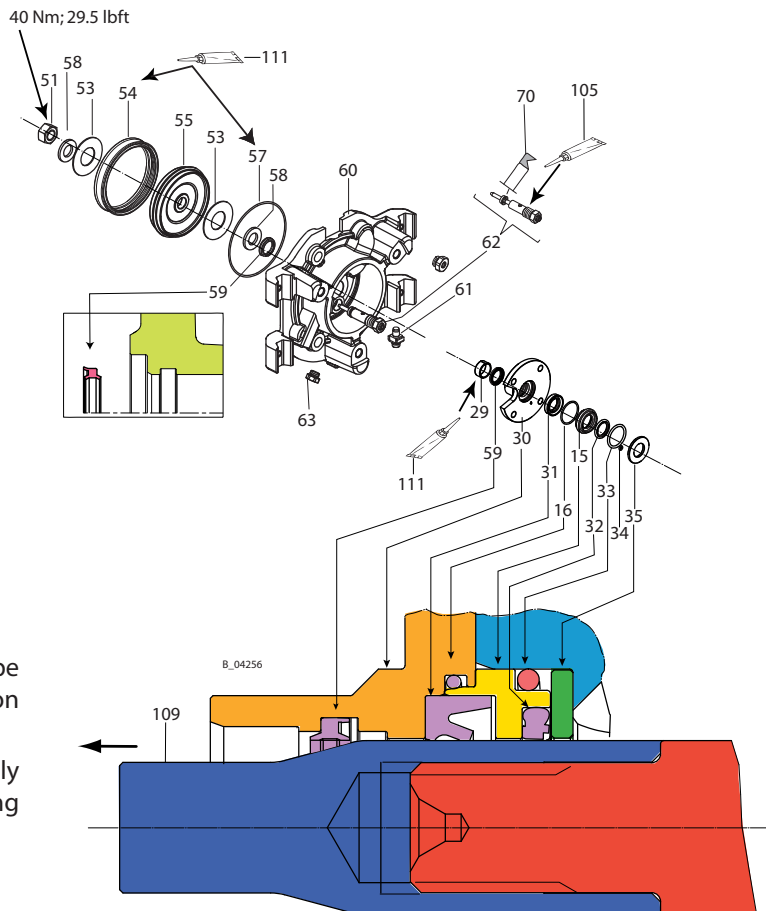

Note:

The piston rod (25) may only be mounted with the screwed-on assembly pin (109).

Grease all o-rings and seals lightly with grease (111) before mounting them.

14.8 COBRA 40-10 INLET VALVE

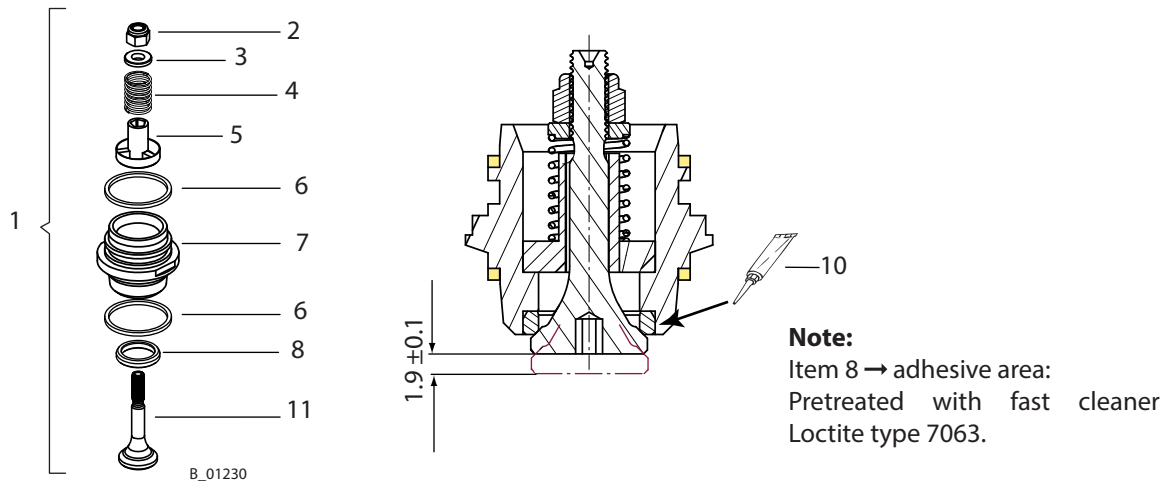

Pos	K	Stk	Order No.	Designation
1	◆	1	322914	Complete Cobra 40-10 inlet valve set
2		2	9912100	Hexagon nut with clamp
3		2	344334	Spring guide
4		2	190304	Pressure spring
5		2	158333	Guide
6	◆	4	341331	Sealing ring
7		2	344322	Valve housing
8	◆	2	340346	Valve seat
10	◆	1	9992528	Loctite 270 50 ml; 50 cc
11		2	340342	Valve cone

◆ = Wearing part.

14.9 INLET VALVE DEPRESSOR

Pos	K	Stk	Order No.	Designation
1		1	341241	Inlet valve depressor, complete
2		1	9922724	Lock washer 3.2
3		1	341377	Sleeve
4		1	9994275	Pressure spring
5	◆	1	9971486	O-ring, 4x2
6	◆	1	341316	Scraper
7		1	341375	Screw plug

◆ = Wearing part.

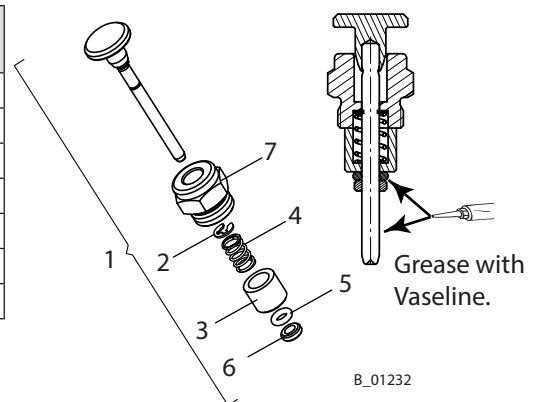

OPERATING MANUAL



14.10 COBRA 40-25 INLET VALVE

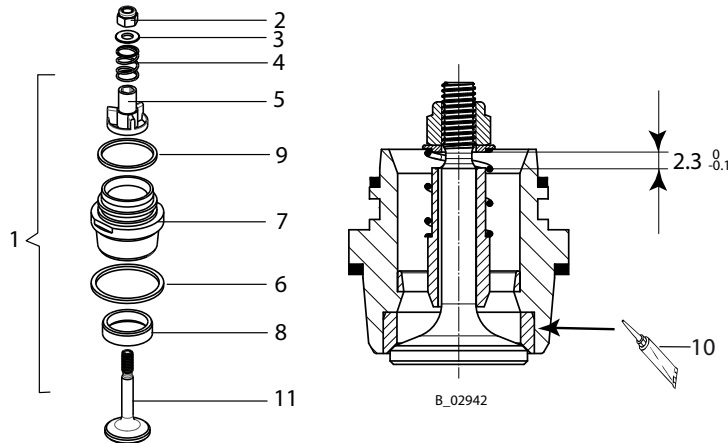

Note:
Item 8 → adhesive area:
Pretreated with fast cleaner Loctite
type 7063.

Pos	K	Stk	Order No.	Designation
1	◆	1	2308753	Complete Cobra 40-25 inlet valve set
2		2	9912100	Hexagon nut with clamp
3		2	253324	Spring guide
4		2	9994304	Pressure spring
5		2	341344	Valve guide
6	◆	2	341330	Sealing ring
7		2	--	Valve housing
8	◆	2	341385	Valve seat
9	◆	2	341331	Sealing ring
10		1	9992528	Loctite 270 50 ml; 50 cc
11	◆	2	341395	Valve cone

◆ = Wearing part.

14.11 RELIEF VALVE

Pos	K	Stk	Order No.	Designation
1	◆	1	169248	Relief valve, complete
2		1	9920602	Adjusting washer
3		1	169346	Pressure spring
4		1	9920202	Washer
5	◆	1	9971395	O-ring, 10x1.25
6	◆	1	9971486	O-ring, 4x2
7		1	9992528	Loctite 270, 50 ml; 50 cc
8	◆	1	9971367	Spiral baking ring 4.78x1.78

◆ = Wearing part.

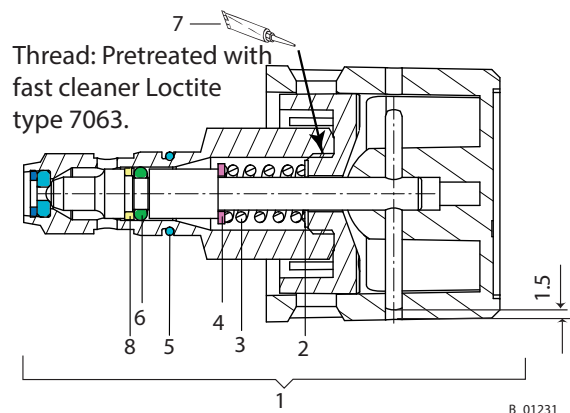

B_01231

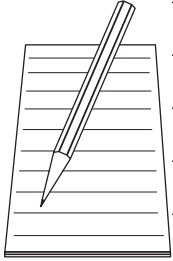

A series of horizontal lines for writing, starting from the top right of the notepad icon and extending across the width of the page. There are 18 lines in total, providing a structured area for notes or instructions.



14.12 HIGH-PRESSURE FILTER (UP TO 530 BAR; 7687 PSI)

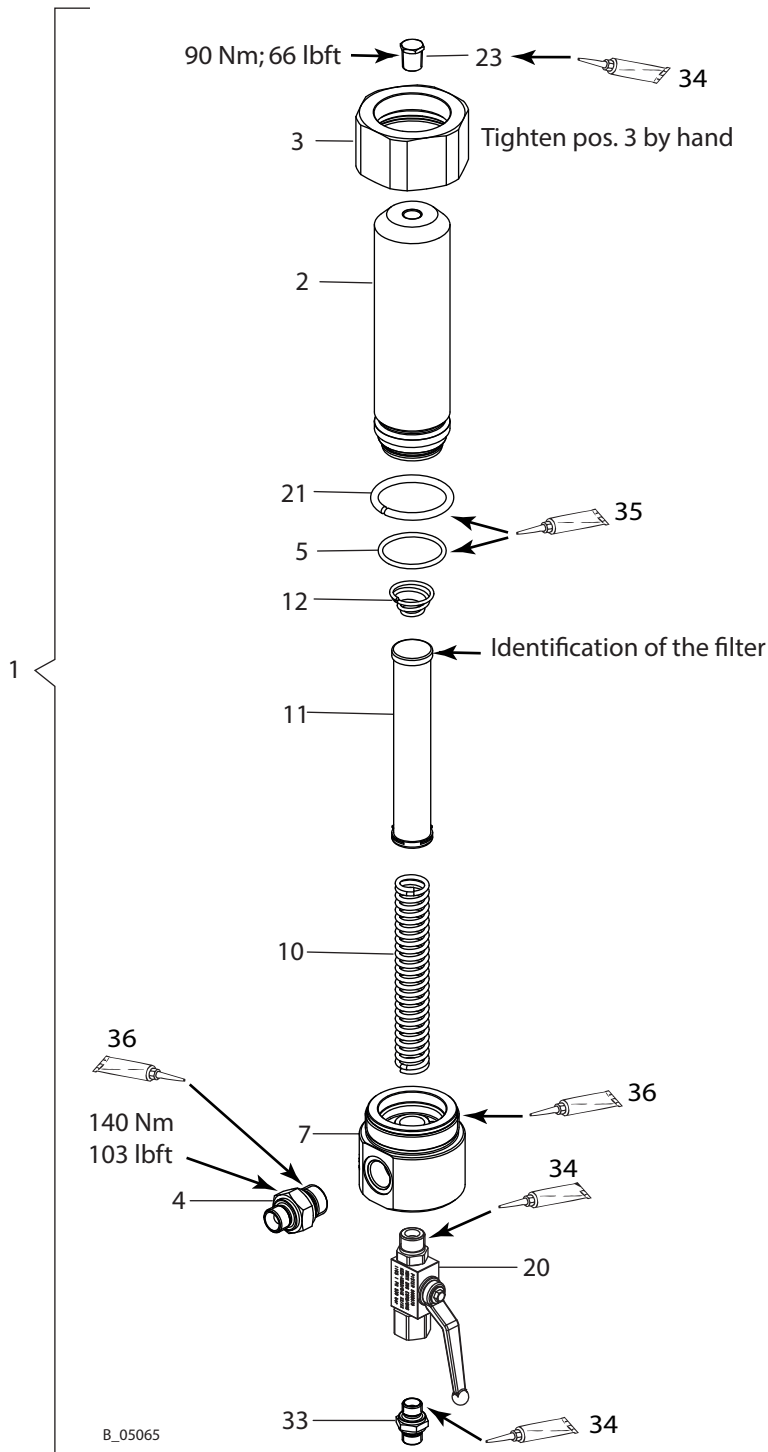

Ball valve version in carbon steel

Pos	K	Stk	Order No.	Designation
1		1	2335334	HP filter DN12-PN530, complete
2		1	2324542	Filter housing
3		1	2324543	Union nut
4		1	2330780	Fitting, DF-MM-G1/2-G3/8-PN530-SSt
5	◆	1	9955863	O-ring
7		1	2324670	Distribution housing for ball valve
10		1	9894245	Filter support
11	◆	1		Filter sieve *
	◆ ●		295721	* Filter sieve 200
	◆		3514068	* Filter sieve 100
	◆ ●		3514069	* Filter sieve 50
	◆ ●		291564	* Filter sieve 20
12	◆	1	3514058	Cone spring
20	◆	1	9998679	Ball valve
21		1	2325562	Pressure ring d45
23		1	2323718	Hexagon plug
33		1	2325826	Double connector
34		1	9992831	Loctite 542 50 ml; 50 cc
35		1	9998808	Mobilux EP2 grease
36		1	9992609	Anti-seize paste tube

◆ = Wearing part.

● = Not part of the standard equipment but available as a special accessory.

14.13 INLINE FILTER 90° (UP TO 270 BAR; 3916 PSI)

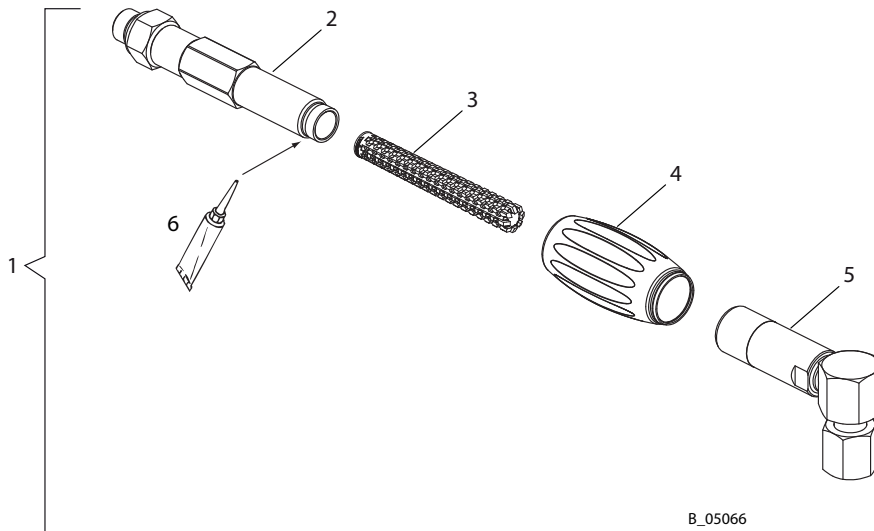

B_05066

Pos	K	Stk	Order No.	Designation
1		1	2329026	Inline filter, HL DN6-PN270-G1/4"-SSt
2		1	2326045	Filter inlet housing, pre-assembled
3	◆	1	--	Filter insert, yellow (middle), 100 mesh per inch*
3	◆ ●	1	2315723	*Filter insert, red (fine), 200 mesh per inch, 10 pieces
3	◆ ●	1	2315724	*Filter insert, blue (middle), 150 mesh per inch, 10 pieces
3	◆ ●	1	2315725	*Filter insert, yellow (middle), 100 mesh per inch, 10 pieces
3	◆ ●	1	2315726	*Filter insert, white (coarse), 50 mesh per inch, 10 pieces
4		1	2311491	Turning handle
5		1	2325950	Filter outlet housing 90°, pre-assembled
6		1	9992609	Anti-seize paste tube

◆ =Wearing part.

● = Not part of the standard equipment but available as a special accessory.

14.14 STRAIGHT INLINE FILTER (UP TO 270 BAR; 3,916 PSI)

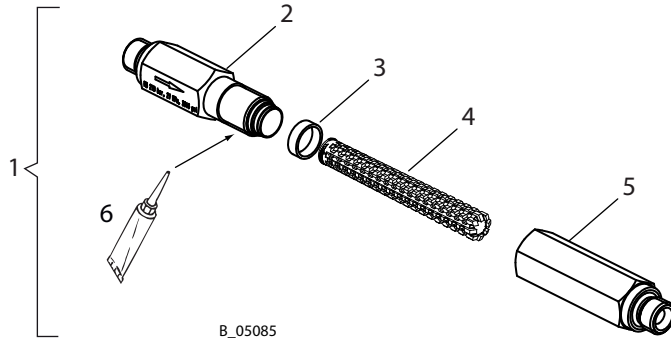

Pos	K	Stk	Order No.	Designation
1		1	2324558	Inline filter DN6-PN270-G1/4"-SSt
2		1	2324550	Filter inlet housing
3	◆	1	128389	Seal
4	◆	1	--	Filter insert, yellow (middle), 100 mesh per inch*
4	◆ ●	1	2315723	*Filter insert, red (fine), 200 mesh per inch, 10 pieces
4	◆ ●	1	2315724	*Filter insert, blue (middle), 150 mesh per inch, 10 pieces
4	◆ ●	1	2315725	*Filter insert, yellow (middle), 100 mesh per inch, 10 pieces
4	◆ ●	1	2315726	*Filter insert, white (coarse), 50 mesh per inch, 10 pieces
5		1	2324551	Filter outlet housing
6		1	9992609	Anti-seize paste tube

◆ =Wearing part.

● = Not part of the standard equipment but available as a special accessory.



14.15 AIRCOAT REGULATOR AND AIRCOAT FILTER REGULATOR

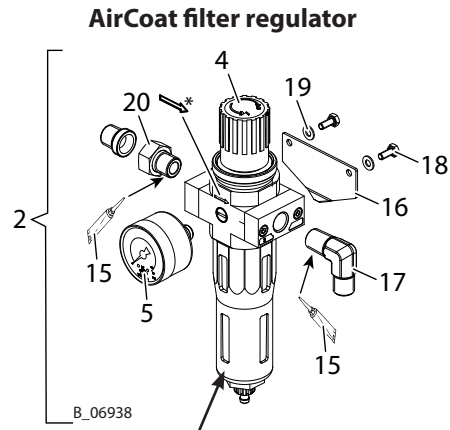
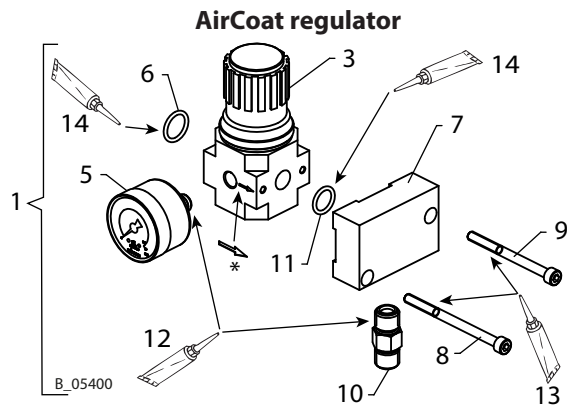

Remove protective container. Mount contact plate. Screw on / unscrew protective container three times (provides contact point via container coating)

Pos 3 or 4:

* Observe the flow direction (direction of arrow to the housing)

Pos 5:

Screw in the pressure gauge until the white sealing ring is completely in the filter control valve. Thereafter continue turning the pressure gauge only to align the display scale.

Pos	K	Stk	Order No.	Order No.	Designation
1		1	2328611	/	AirCoat regulator set
2		1	/	2382997	AirCoat filter regulator set
3	◆	1	2309972	/	Pressure regulator, LR-1/4-D-O-I-Mini
4	◆	1	/	2331950	Filter control valve (manual drain)
			/	2360259	Option: filter pan (automatic drain)
5	◆	1	9998677		Pressure gauge, 0-10 bar RF40 (d40)
6	◆	1	9974166	/	O-ring
7		1	2325527	/	Holding plate
8		1	9906021	/	Hexagon socket cylinder head screw
9		1	9900320	/	Hexagon socket cylinder head screw
10		1	9994627	/	Double fitting R1/4-R1/4
11	◆	1	9971313	/	O-ring
12		1	9992831	/	Loctite® 542
13		1	9992616	/	Molykote® DX grease
14		1	9998808	/	Mobilux® EP 2 grease
15		1	/	9992528	Loctite® 270
16		1	/	2366466	Contact plate
17		1	/	2389277	Fitting, EF-MM-G1/4-R1/4-530 bar
18		2	/	9900152	Hexagon screw without shaft
19		3	/	9920104	Washer
20		1	/	9998719	Double nipple, detachable

◆ = Wearing part.

14.16 COBRA 40-10 FRAME, COMPLETE

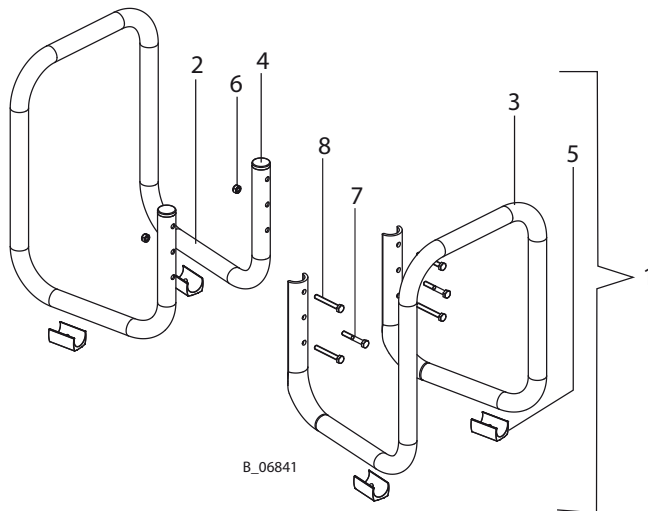

Pos	K	Stk	Order No.	Designation
1		1	322052	Cobra 40-10 frame
2		1	--	Frame pressed
3		1	--	Frame pipe
4		2	9990861	Plug
5	◆	4	9999209	Saddle feet for round tubes
6		2	9910204	Self-locking hexagon nut, M6
7		2	9900202	Hexagon screw M6x40
8		4	9900126	Hexagon screw M6x45

◆ = Wearing part.

14.17 COBRA 40-25 FRAME, COMPLETE

Pos	K	Stk	Order No.	Designation
1		1	2308732	Cobra 40-25 frame
2		1	--	Frame pressed
3		1	--	Frame pipe
4		2	9990861	Plug
5	◆	4	9999209	Saddle feet for round tubes
6		2	9910204	Self-locking hexagon nut, M6
7		2	9900202	Hexagon screw M6x40
8		4	9900126	Hexagon screw M6x45

◆ = Wearing part.

14.18 HORIZONTAL COBRA TROLLEY

Axle setting
Cobra trolley

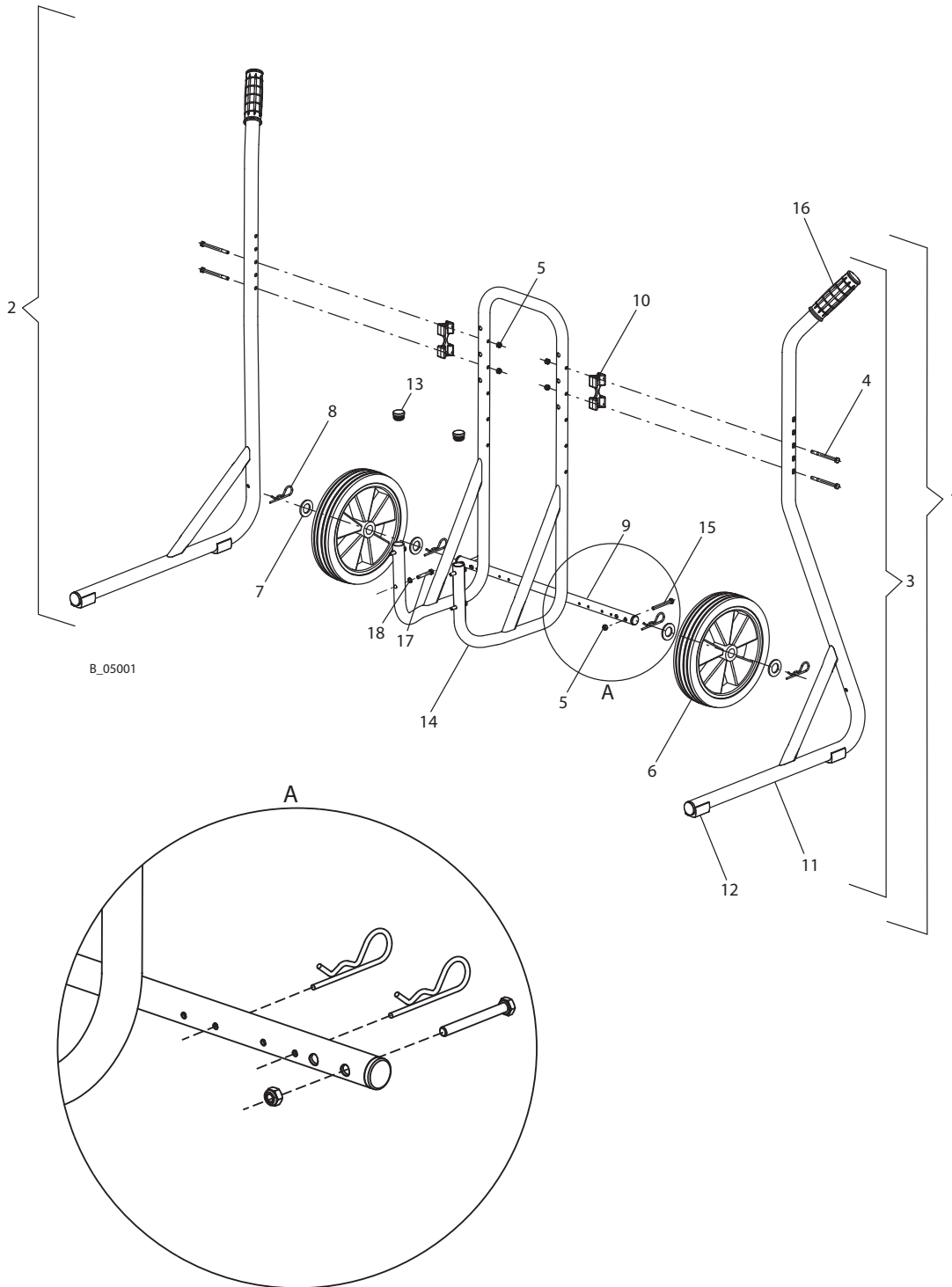

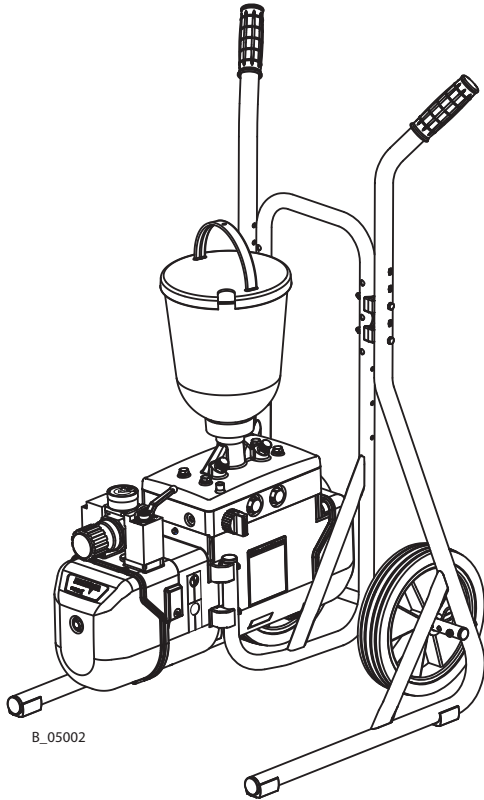
Trolley and pump fitted

Pos	K	Stk	Order No.	Name
1		1	2341375	Cobra trolley complete
2		1	--	Frame, left 4"-6"
3		1	--	Frame, right 4"-6"
4		4	9907140	Hexagon screw
5		6	9910204	Self-locking hexagon nut, M6
6	◆	2	2304440	Wheel, D250
7		4	340372	Washer
8		4	9995302	Cotter pin
9		1	--	Wheel axle 4"-6" complete
10	◆	2	367943	Connecting part 4"-6"
11		2	--	Tube plug, ribbed
12	◆	4	9998685	Saddle feet for round tubes
13		2	--	Plug
14		1	--	Frame pipe long
15		2	3061695	Hexagon screw without shaft
16	◆	2	9998747	Handle
17		4	3051666	Hexagon screw M6x40
18		4	9922017	Serrated lock washer, externally toothed
19		1	2341412	Assembly manual of Cobra trolley horizontal

◆ = Wearing part.

14.19 SLIDING TABLES

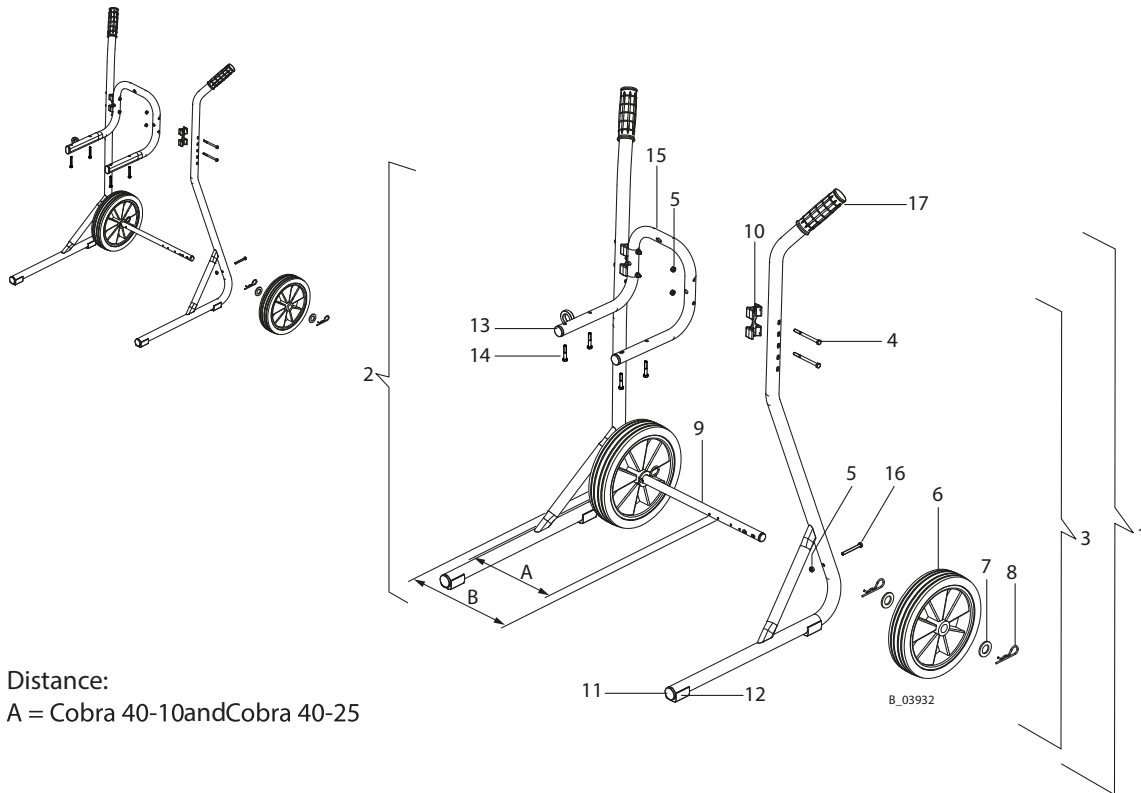

Distance:
A = Cobra 40-10 and Cobra 40-25

Pos	K	Stk	Order No.	Designation
1		1	2325901	Trolley, complete
2		1	--	Frame, left, 4"-6" (welded)
3		1	--	Frame, right, 4"-6" (welded)
4		4	9907140	Hexagon screw DIN931 M6x75
5		6	9910204	Self-locking hexagon nut, M6
6	◆	2	2304440	Wheel, D250
7		4	340372	Washer
8		4	9995302	Cotter pin
9		1	--	Wheel axle 4"-6"
10	◆	2	367943	Connecting part 4"-6"
11		2	--	Tube plug, ribbed
12	◆	2	9998685	Saddle feet for round tubes
13		2	--	Plug
14		4	9900218	Hexagon screw
15		1	2332143	Wall mount
16		2	3061695	Hexagon screw without shaft, M6x55
17	◆	2	9998747	Handle
18		1	2329546	Assembly manual of trolley

◆ = Wearing part.

14.20 COMPLETE HOPPER

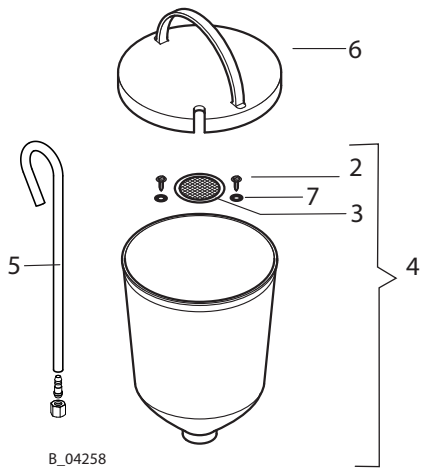

B_04258

Pos	K	Stk	Order No.	Designation
1	◆	1	2344505	Hopper set Ex, 5 L; 1.3 gal
2		2	9902313	Cylinder self-tapping screw
3	◆	1	3756	Filter disk, mesh 0.4 mm; 0.02 inch
3a	◆	1	37607	Filter disk, mesh 0.8 mm; 0.03 inch
4	◆	1	340265	Hopper Ex
5	◆	1	2333163	Relief tube 5 L, complete
6	◆	1	340429	Cover
7		2	9920314	Washer

◆ = Wearing part.

14.21 2 LITER TANK

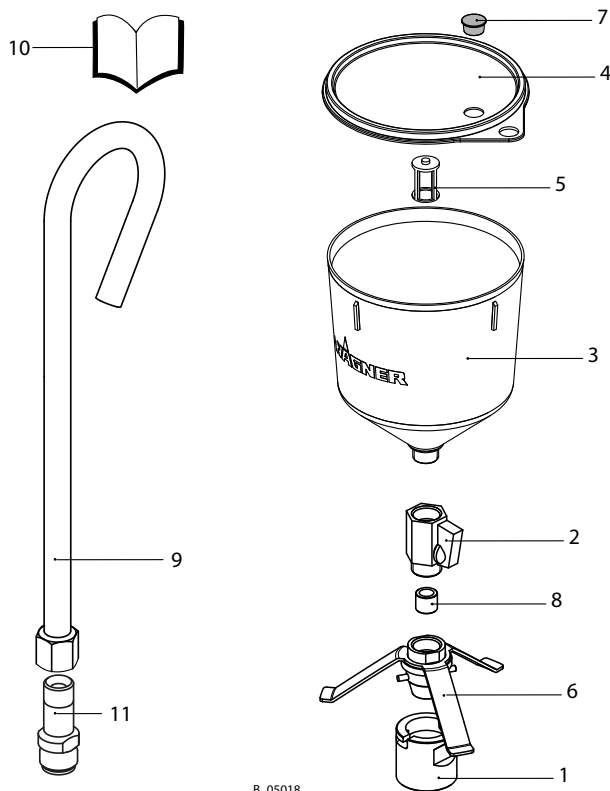

B_05018

*** Replace for the following pumps:**

- Cobra 40-10 with date of product before November 2013.

Pos	K	Stk	Order No.	Designation
		1	2344741	2L Cobra tank
1		1	2320844	Union nut with bayonet
2	◆	1	2321426	Low-pressure mini ball valve, G1/2
3		1	2341277	2 l tank
4		1	2341532	Cover
5	◆	2	2321676	Sieve insert SPA easy line
6		1	2320888	Cone connector preassembled
7		1	9990623	Protection plug
8	◆	1	2320922	Sealing sleeve
9	◆	1	2333163	Exhaust pipe 2L / 5L assy.
10		1	2347181	Assembly Manual
11*		1	2330810	Connection piece

◆ = Wearing part.

15 GUARANTEE AND CONFORMITY DECLARATIONS

15.1 IMPORTANT NOTES ON PRODUCT LIABILITY

As a result of an EC regulation effective from January 1, 1990, the manufacturer shall only be liable for his product if all parts originate from him or are approved by him, and if the devices are properly mounted, operated and maintained.

The manufacturer will not be held liable or will only be held partially liable if third-party accessories or spare parts have been used.

With genuine WAGNER accessories and spare parts, you have the guarantee that all safety regulations are complied with.

15.2 WARRANTY CLAIM

Full warranty is provided for this device:

We will at our discretion repair or replace free of charge all parts which within 24 months in single-shift, 12 months in 2-shift or 6 months in 3-shift operation from date of receipt by the purchaser are found to be wholly or substantially unusable due to causes prior to the sale, in particular faulty design, defective materials or poor workmanship.

The type of warranty provided is such that the device or individual components of the device are either replaced or repaired as we see fit. The resulting costs, in particular shipping charges, road tolls, labor and material costs will be borne by us except where these costs are increased due to the subsequent shipment of the device to a location other than the address of the purchaser. We do not provide warranty for damage that has been caused or contributed to for the following reasons:

Unsuitable or improper use, faulty assembly or commissioning by the purchaser or a third party, normal wear, negligent handling, defective maintenance, unsuitable coating products, substitute products and the influence of chemical, electrochemical or electrical agents, except when the damage is attributable to us.

Abrasive coating products such as red lead, emulsions, glazes, liquid abrasives, zinc dust paints and so forth reduce the service life of valves, packings, spray guns, nozzles, cylinders, pistons etc. Wear and tear due to such causes are not covered by this warranty. Components that have not been manufactured by WAGNER are subject to the original warranty of the manufacturer.

Replacement of a component does not extend the period of warranty of the device.

The device should be inspected immediately upon receipt. To avoid losing the warranty, we or the supplier company are to be informed in writing about obvious faults within 14 days upon receipt of the device. We reserve the right to have the warranty compliance met by a contracting company. The services provided by this warranty are dependent on evidence being provided in the form of an invoice or delivery note. If the examination discovers that no warranty claim exists, the costs of repairs are charged to the purchaser. It is clearly stipulated that this warranty claim does not represent any constraint on statutory regulations or regulations agreed to contractually in our general terms and conditions.

Wagner International AG

15.3 EU DECLARATION OF CONFORMITY

We hereby declare that the supplied version of diaphragm pumps and spray packs:

Cobra 40-10

Cobra 40-25

complies with the following guidelines:

2006/42/EC
2014/34/EU (ATEX Directive)

Applied standards, in particular:

EN ISO 12100:2010	EN 12621: 2006+A1: 2010
EN 809: 1998+A1:2009+AC:2010	EN 1127-1:2011
EN ISO 4413:2010	EN ISO 80079-36:2016
EN ISO 4414:2010	EN ISO 80079-37:2016
EN ISO 13732-1:2008	EN ISO/IEC 80079-34:2011
EN 14462:2015	

Applied national technical standards and specifications, in particular:

DGUV Regel 100-500 Chapter 2.29 and Chapter 2.36	TRGS 727
--	----------

Identification:   II 2 G Ex h IIB T6 Gb X

EU Declaration of Conformity

The EU Declaration of Conformity is enclosed with this product. If needed, further copies can be ordered through your WAGNER dealer by specifying the product name and serial number.

Order number: 2302350

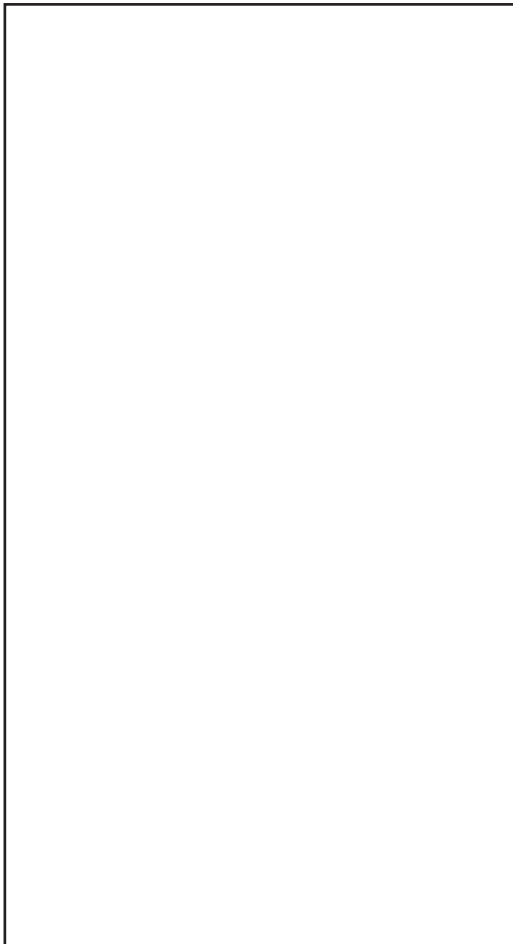

Order No. 2340851
Edition 01/2018

Germany

J. Wagner GmbH
Otto-Lilienthal-Str. 18
Postfach 1120

88677

Markdorf

Phone +49/ (0)7544 / 5050
Telefax +49/ (0)7544 / 505200
E-Mail ts-liquid@wagner-group.com

Switzerland

Wagner International AG
Industriestrasse 22

9450

Altstätten

Phone +41/ (0)71 / 757 2211
Telefax +41/ (0)71 / 757 2222

More contact addresses:
www.wagner-group.com

Subject to changes without notice